

200 bauds start - stop regenerator

S. K. DAS, K. SUNDARAM and K. C. PANT

Meteorological Office, New Delhi

(Received 15 June 1981)

सार — दीर्घ और मध्यम संवहन/कर्षणस्थल तारों और रेडियो परिपथ पर दूरमुद्रक संकेत विकृत हो जाते हैं जिससे उनके मिश्रित अभिग्रहण की वजह से सूचना के आदान प्रदान में देर हो जाती है। इस तरह से लेखकों ने विकृतियों को कम से कम करके उनको ठीक करने के लिये, एक प्रवर्तन निवर्तन पुनःजनित का अभिकल्पन किया है। जिससे मुद्रण प्रणाली द्वारा संकेत प्राप्त किये जा सकें।

विकसित अभिकल्पन परिपथ सरल है और विकृतियों को 49 प्रतिशत तक ठीक करने में सक्षम है तथा यह चाल में ± 10 बाँड के परिवर्तन को समायोजित कर सकता है। इस पुनःजनित को 50, 75, 100 और 200 बाँड की गति पर प्रचालन करने वाले परिपथों पर उपयोग में लाया जा सकता है।

ABSTRACT. Teleprinter signals on long and medium haul land-line and radio circuit get distorted causing delay in exchange of information due to its garbled reception. The authors have designed a simple start-stop regenerator to correct the distortions to the minimum to enable the acceptance of signals by the printing system.

The design evolved is simple in its circuitry capable of correcting distortions upto 49 per cent and also can accommodate a speed variation of ± 10 bauds. The regenerator can be used on circuits operating on 50, 75, 100 and 200 bauds speed.

1. Introduction

1.1. Distortions can occur due to two main reasons. These are bias distortion and distortion due to other factors of random nature. The first gives a regular and consistent distortion due to equipment misalignment between trans-receive system. Its effect is to make the start or the space elements longer than they should be and thus making the mark elements shorter. The reverse process is also possible. This can be corrected by proper maintenance of the terminal gears.

1.2. The second form of distortion is of random nature and is quite unpredictable. Generally this is caused by external influences upon the communication link, like sporadic interference bursts on radio links, induced impulses through cross-talk pick up on lines running through telephone exchanges etc.

1.3. The telegraph transmission is always on character by character basis. A character is transmitted completely independent to the previous or the following character.

1.4. Therefore, a character regenerator accepting distorted signal and producing a correct one is necessary to eliminate such distortion. The regenerator should have the means to scan the incoming elements and reconstruct the element to the correct width before feeding to the printing system.

2. Principle of operation (Fig. 1)

2.1. A start-stop regenerator should be able to (i) start and stop in synchronisation with each character given to it; (ii) identify both kind of distortions; (iii) and correct the same and (iv) guard itself from getting switched by random interruptions (flicks) shorter than 2.5 ms when the circuit is on idling state.

2.2. The input is applied to a voltage divider DIV (Fig. 1) to make it compatible to the operating stages. The received elements are passed through a shaping circuit (PC). On receipt of the start polarity, a start synchroniser (SYC) is triggered to enable it to start (i) the local oscillator (OSC), (ii) unlatch the

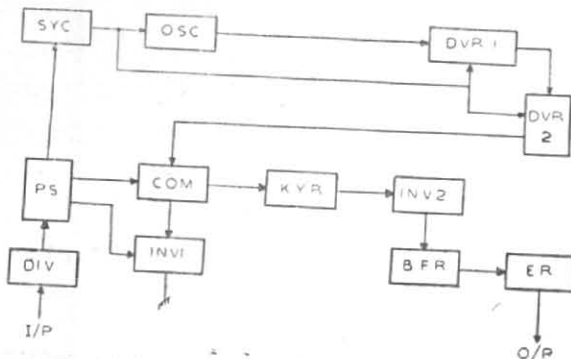

Fig. 1. Block diagram: Regenerator 200 bauds

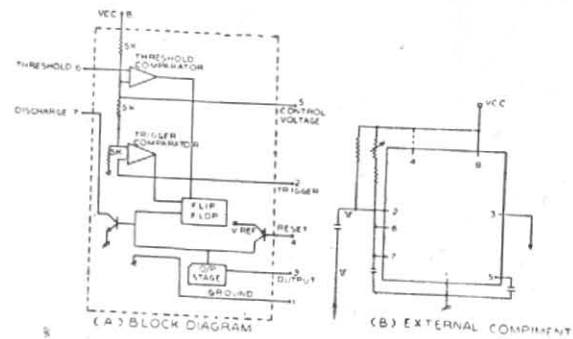

Fig. 2. (A-B). 1C Functional diagram: (A) Block diagram; (B) External complementary

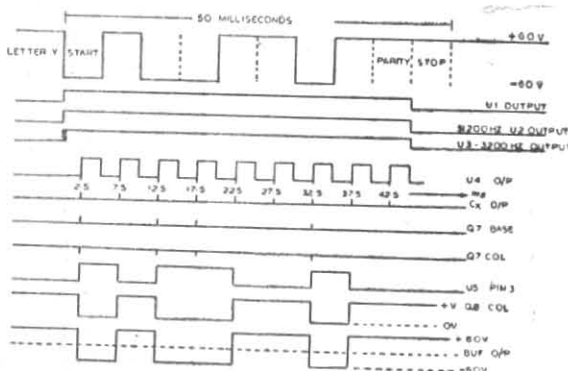

Fig. 3. Timing stream

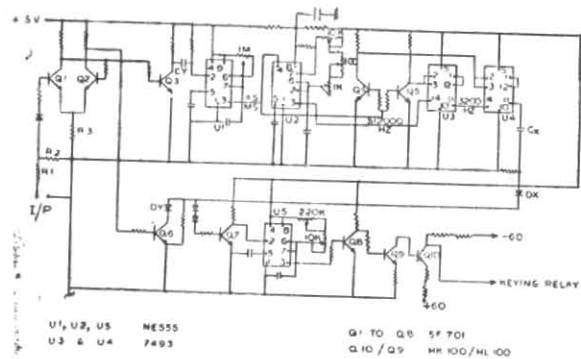

Fig. 4. Schematic diagram start-stop regenerator 200 bauds

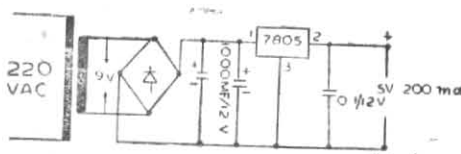

Fig. 5. Power supply

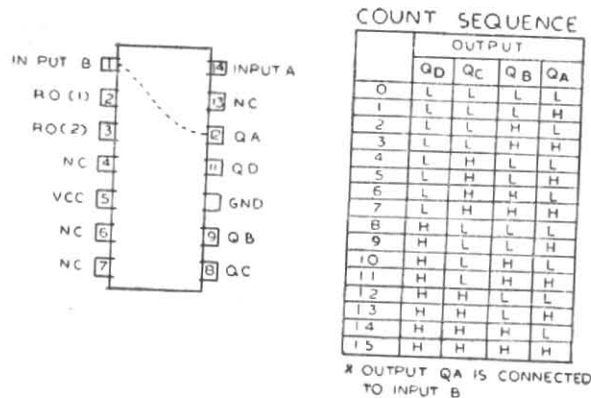

Fig. 6. Count reference of IC 7493

divider counters (DVR 1 and DVR 2) to enable to start their functions. The SYC maintains on operational condition for 45 ms and automatically resets itself disabling OSC, DVR 1 and DVR 2.

2.3. The master oscillator (OSC) on trigger from SYC starts a 51, 200 HZ pulse train. The clock pulses thus obtained get divided by 16 by DVR 1 and a further division is made by 16

by DVR 2 to get an output pulse at every 5 ms interval.

2.4. The output of DVR 2 is differentiated and given to the comparator (COM) to be compared with the incoming element at the COM from PS to determine the polarity of the received element.

2.5. The incoming element at PS when sensed to be of a mark polarity the scan pulse arriving

at COM gets driven to the ground by the mark sense inverter INV 1. But if a space is sensed at PS, it gets compared at COM and the resultant output keys KYR, a 5 ms monostable. The output passes through INV 2 to BUF and then to the O/P relay.

2.6. The unit has undergone a live test on the circuit and found to be satisfactory.

3. Description of operation (Fig. 4)

3.1. The main system consists of three accurately tuned timers, 11 transistors and other coupling components in addition to two 7493 binary counters. The functional diagram of the IC used along with its external complementary hook up is shown in Fig. 2 (A-B). The timings stream at different phases of the circuit is indicated in Fig. 3.

3.2. The input is applied through the voltage divider RIR 2 to the pulse shaper Q1-Q2-R3. When the input is on mark, Q1 and Q6 would be on conduction while Q2 and Q3 would stay passive. The power supply used is shown in Fig. 5.

3.3. When the start polarity is applied to Q1, it instantaneously (i) runs Q2-Q3 to ground and (ii) unlatches Q6 from ground. The negative going spike on CY switches or sets on a 45 ms self resetting toggle U1. The output obtained is applied to U2, Q4 and Q5 for further functioning of the system.

3.4. The 45 ms output from U1 is applied to pin 4 of U2 to reset U2 from quiescent condition, and also to Q4 and Q5 to place U4 and U3 on standby to start counting by applying a 'set' command.

3.5. When U2 is removed from its quiescent condition, it oscillates and supplies the clock frequency at 51200 HZ. The clock pulse train gets divided by 16 by the binary counter U3 (7493). Count reference of IC 7493 is depicted in Fig. 6. The resultant 3200 HZ is applied to and further divided by 16 by U4 to get an output of 200 HZ or in other words a pulse at an interval of 5 ms. The counter output stays

low during the first 100 HZ and go high for the other 100 HZ. Thus it may be seen that a pulse of 2.5 ms width will be sent out by U4 at an interval of 2.5 ms from the start of the start pulse of the character. (Fig. 3. U4/OP).

3.6. Due to the action of commuting capacitor-diode $C_x - D_x$, a series of positive trigger spikes at 2.5, 7.5, 12.5, 17.5, 22.5, 27.5, 32.5, 37.5 and 42.5 milliseconds. (Fig. 4. C_x /OP) will be registered at the output of D_x , after sensing of the start element of the character.

3.7. If the incoming element is sensed to be a mark, the clocking pulse from D_x sinks to ground through DY-Q6 (3.2).

3.8 If a space element is sensed Q6-DY gets unclamped from ground (3.3) and the compared trigger pulse would be available for further use. Therefore, it is evident when compared with a space element, a trigger pulse would be available at the base of Q7 (Fig. 3-Q7 base).

4. Regeneration (Fig. 4, Q7-U5)

4.1. In quiescent condition of Q7, U5 remains passive. Keeping Q8 inactive. This bias Q9 of the buffer Q9-Q10 allowing a mark (+ 60V) at its output. When a space element is sensed at the input, the comparator O/P (3.6) actuates Q7. The sinking of Q7 to ground triggers U5, a 5 ms mono (Fig. 3/U5). This causes the removal of bias from Q9 which changes the output of the buffer from mark to space (- 60V) (Fig. 3/BUF/OP).

4.2. The action of Q7-U5 sends out, or regenerates a fresh pulse (element) with the proper width of 5 ms and amplitude to the buffer. Since the sampling is done after 2.5 ms of the receipt of the character start (i.e., the latter half of the element) there would be a delay of 2.5 ms between the input and the corrected output.

4.3. Since the sampling is done at the centre, obviously the system is expected to accommodate and correct a distortion of 50 per cent. Theoretically though reasonable yet due to components behaviour, the system can reach upto 49 per cent.

4.4. The flow diagram of Fig. 3 indicates the different phases of selection for letter "Y" from its receipt to its utilisation.

5. Buffer (Fig. 4, Q9-Q10)

5.1. The electronic relay designed by R and D for general use to operate on dual polarity is used here as the output device. The keying pulse available from Q8 is the neutral and also of low voltage. Therefore, Q9-Q10 acts as a buffer to transform the output of Q8 to make it compatible for the operation of the output device (ER).

6. Start-stop cycle

6.1. At the end of the parity element of the character (45 ms) U1 resets the whole sequential operation by resetting itself automatically and start afresh when the start element of the succeeding character is sensed. The whole sys-

tem thus, stops and starts afresh for every individual input given to it.

6.2. Releasing of U1, 5 ms prior to the end of the character cycle, help resetting the dedicated circuitry before the succeeding start element arrives.

7. Change of baud rate

7.1. The circuit itself is unique in the sense it uses a very few components and incorporates a great amount of reliability and flexibility in its operation.

7.2. By readjusting the trimmers of U1, U2 and U5, the baud rate can be changed to cover the ranges between 25 bauds and 300 bauds.

References

- Das, S. K., Sundram, K., and Pant, K. C., 1981, An Electronic Relay for telecommunication equipment, *Mausam*, 32, 3, pp. 229-230.
- Signatic data manual, 1976, signatic corporation Inc.