

## Computerised calibration system for radiosonde pressure sensors

S. K. SRIVASTAV, M. K. GUPTA and K. L. BHARADWAJ

*Meteorological Office, New Delhi*

(Received 17 June 1991, Modified 23 June 1992)

**सार** — एम के III भारतीय रेडियो सौन्दों में प्रयुक्त दबाव संवेदकों के अंशांकन के लिए कम्प्यूटर आधारित आंकड़ा अधिग्रहण प्रणाली अभिकल्पित की गई है। यह प्रणाली एक चक्र में 64 वायुदाब स्विचों का अंशांकन कर सकती है और विभिन्न सम्पर्क संख्याओं पर दबाव मानों को तालिकाबद्ध मुद्रित सामग्री प्रदान करती है। यह अभिलेखन प्रणाली के समानांतर नमूने का प्रतिस्थापन करती है जोकि पिछले कुछ दशकों से प्रयोग में है। यह प्रणाली अधिक सही और सुदृढ़ है तथा मानवीय निर्णय और त्रुटियों से बचाती है।

**ABSTRACT.** A computer based data acquisition system has been designed for the calibration of pressure sensors used in MK III Indian radiosondes. The system can calibrate 64 baroswitches in one cycle and gives a tabular printout of pressure values at various contact numbers. This replaces the analog type of recording system which was in use for the last few decades. The present system gives better accuracy and resolution and avoids human judgement and errors.

**Key words** — Radiosonde system, Intellisensor, Analog data acquisition card, Channel multiplexer, Micro-computer.

### 1. Introduction

Pressure sensor is the most important part of any radiosonde system. In MK III Indian radiosonde, the aneroid capsule made out of Nispan-C is used in a baroswitch mode. As the Nispan-C has zero thermo-elastic coefficient, this was found the most appropriate alloy for making aneroid capsules. Suitably annealed and aged, diaphragms of Nispan-C are soldered and evacuated to  $10^{-5}$  Torr to make the aneroid capsule. Aneroid capsule is thoroughly exercised and mounted on a die-cast frame with one side fixed. On the other free end, a lever arm is mechanically coupled to sharp tipped pen arm which moves with the expansion/contraction of the aneroid, on a printed circuit plate having 150 conducting and non-conducting segments. These segments are spread over an arc of 75 mm radius of curvature, and sector length of 52.5 mm.

The commutator plate contacts, in conjunction with pen arm tip, are used for sequential switching of temperature and humidity sensors to the modulator which converts resistance of sensors into audiofrequency ready for transmission on a carrier. High and low references also intermittently occur to keep check on the health of the radiosonde during ascent.

The pressure values from the baroswitch are deduced by calibrating the movement of pen tip on commutator plate. The calibration procedure comprises of keeping the baroswitches into a thermo-vacuum chamber in which both temperature and pressure are simulated as encountered by radiosonde during its ascent. The pressure values are noted for beginning and end of each contact. The calibration chart, thus obtained, is used for detecting the pressure values in the radiosonde

flight. The accuracy and resolution of pressure measurements entirely depend upon the quality of calibration system used and so the accuracies of radiosonde measurements.

The block diagram of the analog type calibration system is given in Fig. 1. The chamber in which the baroswitches were to be calibrated, was coupled to a manometer tube. A soft iron float on the mercury in the manometer tube acts as a core of a differential transformer. When the float is in the centre of the differential transformer, there is no voltage in its output but when the float moves away from the central position an error voltage is developed. This error voltage is amplified by the servo-amplifier and applied to the control winding of the manometer servo-motor, which is a two phase induction motor. The servo-motor rotates the lead screw which moves the differential transformer on the manometer tube. The servo-motor rotates either direction depending on the phase of the error voltage. The error voltage is either in phase or  $180^\circ$  out of phase with respect to the phase of the voltage in the primary winding of the differential transformer depending on the direction in which the core is displaced from the centre of the differential transformer. The servo-motor drives the transformer such that the error voltage is minimum and the float is maintained in the central position. The level of mercury in the manometer tube is thus automatically tracked and forms the basis of pressure calibration. The initial and final readings of the auto-manometer are checked and compared with those of a precision mercury manometer, connected in parallel with the thermovac chamber.

The motion of the servo-motor which makes the transformer to follow the column of mercury is transferred to recorders through another servo-chain. This

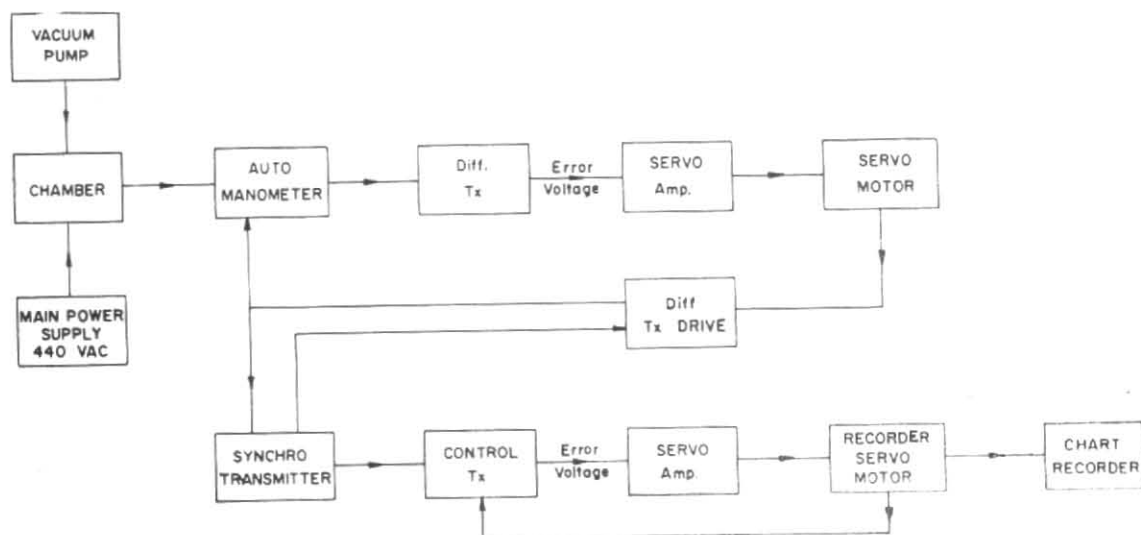

Fig. 1. Block diagram of analog baroswitch calibration system

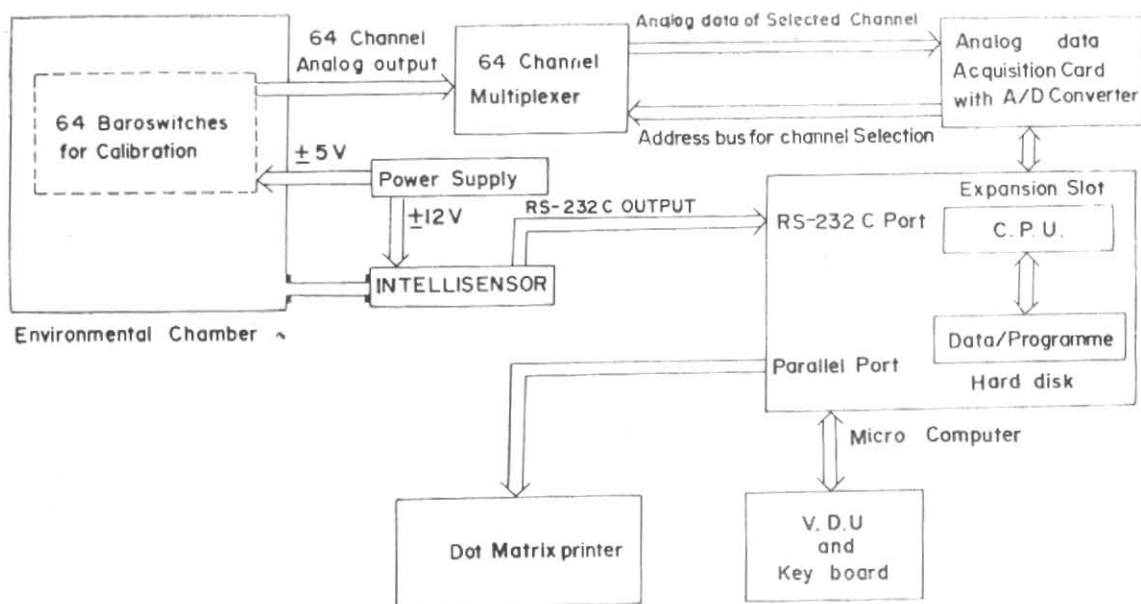

Fig. 2. Functional block diagram of computerised baroswitch calibration system

consists of a 'synchro transmitter' driven by the manometer servo-motor, whose rotation is conveyed to the recorder servo-motor, through the control transformer and servo-amplifier. The recorder chart roll thus moves in synchronism with the mercury level in the manometer tube. This motion is adjusted according to a pre-printed pressure scale on the chart paper such that the paper is advanced to 1 mm with fall of 1 hPa pressure in the chamber.

When the pen attached to the aneroid in the baroswitch makes a contact with a conducting segment of the commutator, the pen on the recorder is deflected and the trace indicates the pressure on the printed chart. Thus, analog type pressure calibration chart is obtained with each mm as 1 hPa and beginning and end of each contact is recorded as trace. The pressure values for each contact number of commutator plate can be read from the chart supplied with each baroswitch

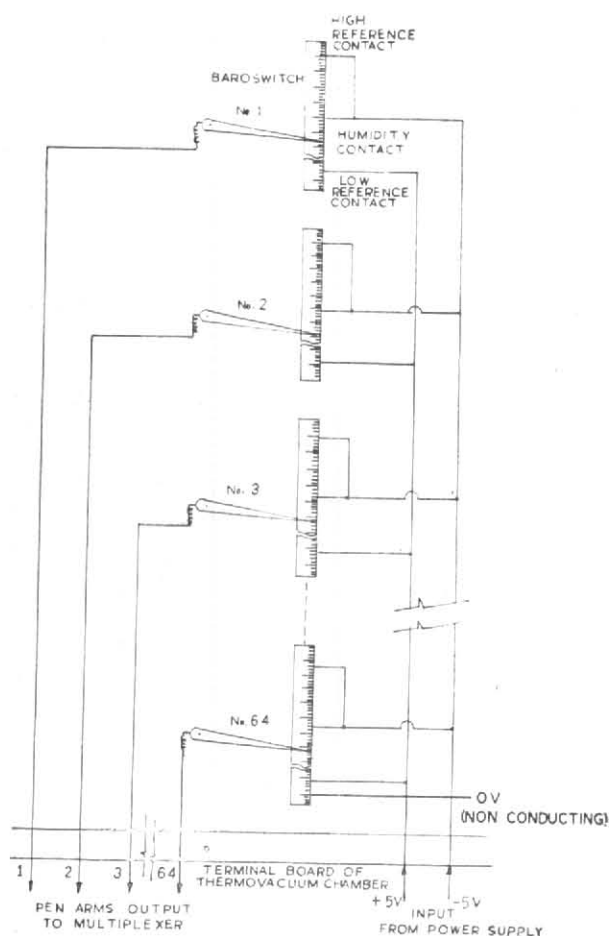

Fig. 3. Wiring diagram of baroswitch during calibration.

This form of calibration system had a number of inherent disadvantages. The sources of inaccuracy and order of error are as follows :

- (i) Lag, lead and/or jerky movement of chart paper which is more serious at low pressure, where higher calibration accuracy is needed, because of slow rate of increase in servo-error signals for both the servo-loops. 1 hPa
- (ii) Switching the chart movement ON at exactly 1020 hPa is very difficult as the pressure is falling rapidly @ 0.5 hPa/sec. 1 hPa
- (iii) Decoding errors due to limited resolution (1 hPa/mm) of chart/human judgement. 0.5 hPa
- (iv) The accuracy in printing of mm line in the chart length could not be better than  $\pm 0.5$  mm/metre. Also the length of chart paper is affected by the ambient humidity condition during calibration which also in turn, introduces calibration errors. 0.5 hPa

As the whole system was mechanical, the wear and tear in the mechanical components were also a major

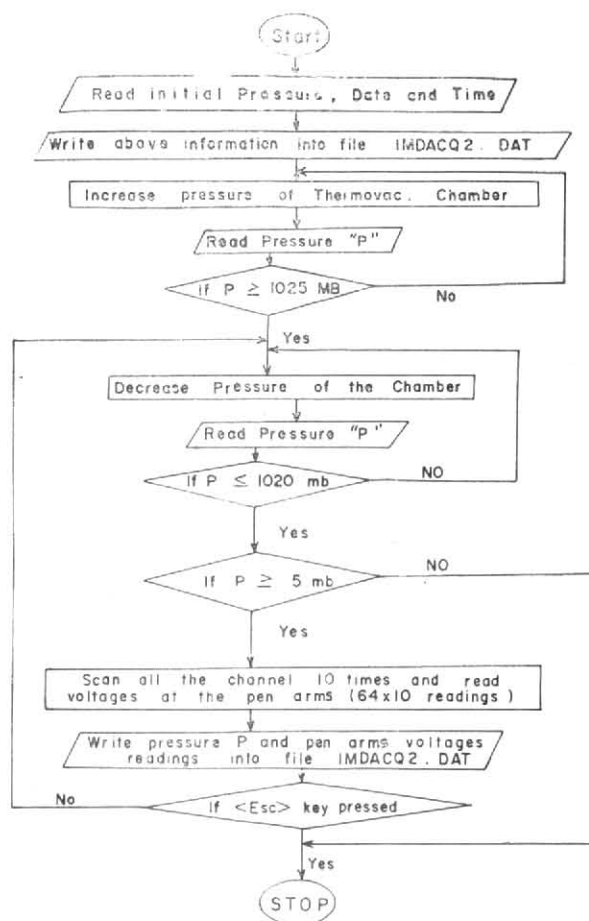

Fig. 4. Flow chart of program IMDACQ

source of inaccuracy. The major lacuna was felt in the system as the calibration chart beyond 50 hPa had less number of ordinates with greater number of contacts, thus making the resolution inadequate at lower pressures. Thus, the radiosonde information at higher height was more prone to errors due to poor resolution and a greater role of human judgement.

Keeping the above in view, it was felt necessary to develop a calibration system having higher resolution and better accuracy. In the present paper, a computer based pressure calibration system has been discussed, using a digital pressure sensor and analog to digital data acquisition system.

## 2. System configuration

The functional block diagram of the computer based digital calibration system designed for the purpose is shown in Fig. 2. The system consists of the following units :

### 2.1. Thermo-vacuum chamber

The thermo-vacuum chamber has a capacity to place 64 baroswitches. All the baroswitches are supplied +5 V power to their low reference contacts and -5 V power to their humidity and high reference contacts

from an external DC power source through the terminal board provided on the body of the chamber as shown in Fig. 3. The pressure and temperature inside the thermovac chamber can be varied from 1025 hPa to less than 5 hPa and  $+50^{\circ}\text{C}$  to  $-50^{\circ}\text{C}$  respectively in a simultaneous predetermined rate. With the change of pressure, pen arm of baroswitch moves over the commutator plate and picks up the voltage available on the baroswitch contact which is  $+5\text{ V}$ ,  $-5\text{ V}$  or  $0\text{ V}$  depending on the position of the pen arm, *i.e.*, at low reference, humidity/high reference or non-conducting part of the commutator plate respectively. To measure this voltage, pen arms of all the baroswitches are individually connected to the multiplexer through the terminal board of the chamber.

## 2.2. Intellisensor

Digital barometer manufactured by Atmospheric Instrumentation Research Inc., USA, with the following specifications, is used as pressure sensing element for the chamber pressure:

Pressure measurement range	: 0 to 1300 hPa
Accuracy	: $\pm 0.6$ hPa
Pressure resolution	: 0.01 hPa
Sampling rate	: 10 per second
Selectable averaging	: 1, 10, 100, 1000 sample/average
Output interface	: RS-232C (110, 300, 1200, 9600 baud)
Output data format	: Serial ASCII, 8 bit, no parity, 2 stop bits
Power requirement	: $\pm 12\text{ V DC}$

It is connected to the environmental chamber through a rubber tube and the output is connected to the RS-232C port of the micro-computer. Averaging of 10 samples per second and transmission speed of 9600 bauds have been selected. In this configuration, it sends one pressure reading every second. This pressure reading is the average pressure of the chamber during last one second interval. An external  $\pm 12\text{ V DC}$  power supply is utilised to supply power to the digital pressure sensor.

## 2.3. 64 channel multiplexer

It is a single pole 64 way electronic switch, and connects one of the baroswitches pen arm's output to the analog data acquisition card for measurement of voltage at the pen arm. The switching action is controlled by 6 bit digital address input from analog data acquisition card. The 6 bit digital address input represents channel No. 0 to 63 in binary form corresponding to the baroswitch connected to the data acquisition card. Thus, all the 64 baroswitches under calibration are multiplexed and sequentially connected to analog data acquisition card.

## 2.4. Analog data acquisition card

This is an interface card to link analog data to PC/XT and also to control the working of multiplexer. It is installed into one of the expansion slots of PC/XT and its working is software controlled. First, a binary

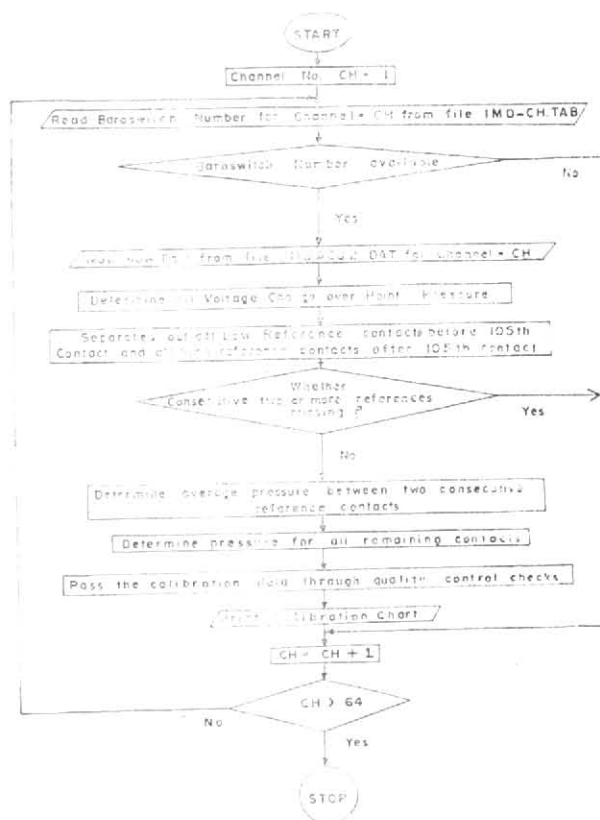

Fig. 5. Flow chart of program process

address is sent from its digital output port to the multiplexer, and then it samples the analog input obtained from multiplexer, converts it into a binary value. This binary number is then read into memory and stored for further processing. This process of data acquisition takes 15 microseconds per channel. The process is fully software controlled and is discussed further while describing software being used for baroswitch calibration.

## 2.5. Micro-computer

The basic configuration of micro-computer used in the system is given below:

- (1) CPU 8088,
- (2) 640 KB (RAM),
- (3) 20 MB Hard Disk Drive,
- (4) 360 KB Floppy Disk Drive,
- (5) Video Terminal,
- (6) RS-232C Port, and
- (7) Parallel Port for Printer.

The PC/XT controls the entire operation of this system. During data acquisition process, which is under control of program IMDACQ, it controls 64 channel multiplexer and analog data acquisition card to acquire raw calibration data. Later on, it processes these data to produce calibration charts individually for all the baroswitches under calibration.

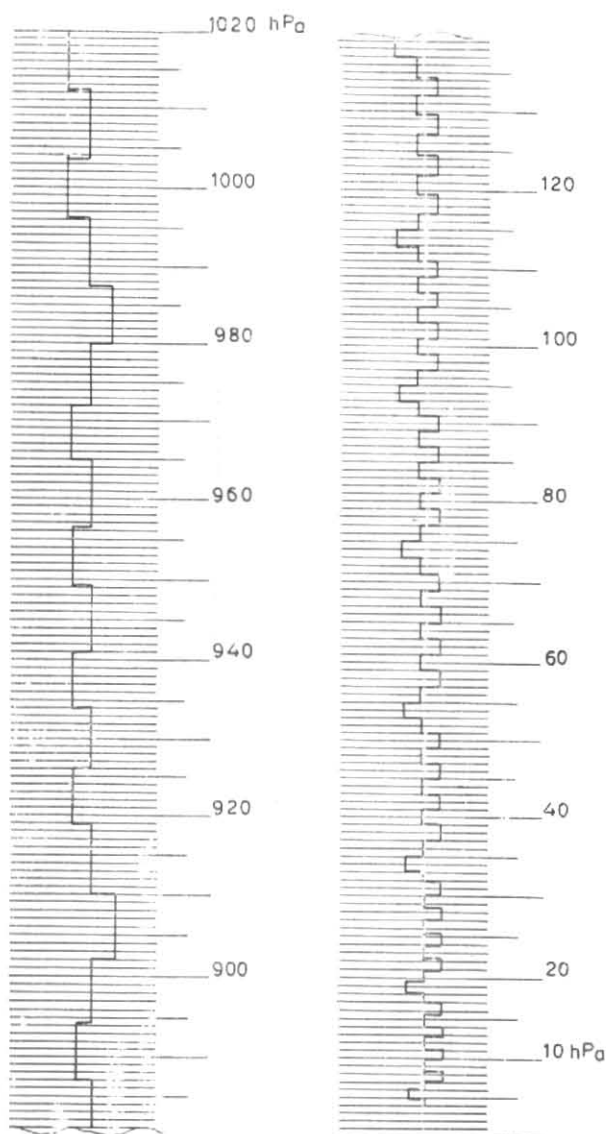

Fig. 6. Baroswitch calibration chart-Analog

3. Software description and operation

In each calibration cycle, maximum 64 baroswitches can be calibrated. All the baroswitches are first visually checked, their commutator plates are cleaned and tension of pen arm is properly adjusted. Checked baroswitches are then mounted in suitable trays and required electrical connections are made as shown in Fig. 3. All the trays containing baroswitches are placed into thermo-vacuum chamber and connected to the inner terminal board.

Following programs are executed in a calibration cycle.

3.1. EC

This program is for entering baroswitch numbers for all the 64 channels. Editing facility is provided by movement of cursor to any of the already entered

TABLE 1

Baroswitch calibration chart-digital

Contact number	0	10	20	. . .	140	150
0.0	-50.0	916.1	792.2	. . .	40.3	10.9
0.5	-50.0	905.5	781.9	. . .	38.4	9.8
1.0	-50.0	900.6	778.2	. . .	37.3	
..	..	..	..	. . .	..	
..	..	..	..	. . .	..	
..	..	..	..	. . .	..	
9.5	918.6	797.2	686.3	. . .	13.3	

Instrument : 1443-90                      Time : 11 : 30 : 02 IST  
 Date : 12 April 1991  
 Surface pressure : 983.0 hPa              Last pressure : 9.7 hPa

Note : -50.0 indicate a missing contact or the contact is outside the bounds of calibration range, i.e., 1020 hPa to 5 hPa.

baroswitch numbers for making desired modification. At the end, by pressing function key F10, all the baroswitch-numbers get stored into a file IMD-CH. TAB.

3.2. CHECK

The execution of this software scans all the 64 channels through the data acquisition card and multiplexer and displays the status on monitor screen. The status is updated continuously at every second. This software facilitate to adjust the pen arm of each baroswitch at 5th contact mechanically (first low reference contact at ambient pressure) and the output voltage at pen arm, when properly adjusted, is +5 V. The program execution can be terminated by pressing any key on the keyboard.

3.3. IMDACQ

This program acquires baroswitch calibration raw data for all the 64 baroswitches. At the beginning of this program, it receives the initial pressure values through RS-232C port from intellisensor, and then allows to enter current date and time and write this data in a file IMDACQ2. DAT. After this step, it asks to raise pressure up to 1025 hPa and then reduce it. As soon as the pressure becomes just less than 1020 hPa, the main data acquisition process starts which repeats the following steps every second till the pressure becomes less than 5 hPa or the program is terminated by pressing Esc key.

- (i) Reads pressure of thermo-vacuum chamber from intellisensor through RS-232C port.
- (ii) Sequentially samples output of pen arms through data acquisition card and multiplexer from channel 1 to 64. This sequential sampling is repeated 10 times every second.



- (iii) Write pressure data and sampled data (640 values) into file IMDACQ2.DAT. The flow chart of the program is shown in Fig. 4.

### 3.4. PROCESS

This program processes the data acquired by IMD-ACQ program to create baroswitch calibration chart for all the 64 baroswitches. Fig. 5 shows the flow chart of the program. Raw data of one baroswitch is read from raw data file IMDACQ2.DAT and its baroswitch number from file IMD-CH.TAB and processes raw data in the following steps :

- (i) Determine all voltage change over pressure values.
- (ii) Separates out low reference contacts before 105th contact and high reference contacts after 106th contact.
- (iii) If two consecutive low references or high references are missing, the further processing for this particular baroswitch is terminated, indicating the defect on monitor screen.
- (iv) Determines average pressure per contact between two consecutive references as fixed above in step (ii) and compares with the actual acquired contact pressures. With this process of comparison, it determines the missing and broken contacts.
- (v) The baroswitch calibration data are then subjected to following quality control checks, enabling to sort out defective baroswitches :
  - (a) Consecutive references should not be missing.
  - (b) Not more than two references be missing.
  - (c) Not more than three consecutive contacts be missing or broken.
  - (d) Not more than 5 contacts be missing or broken.
  - (e) The last contact's pressure be less than 20.0 hPa.
  - (f) The calibration must reach at least 135th contact.
  - (g) The pressure of 5th contact be within  $\pm 5$  hPa of ambient pressure.

- (h) The pressure of 105th contact be between 100 and 250 hPa.

- (vi) The calibration chart is then printed on the printer alongwith result of quality control check, *i.e.*, accepted or rejected alongwith cause of rejection.

These steps (i) through (vi) are repeated for all the 64 baroswitches. However, it is not necessary to use the maximum capacity (64 baroswitches) of calibration in each cycle of calibration. If any channel is not used, the baroswitch number for the corresponding channel is not entered during execution of program EC. In such cases, data of those channels are not processed.

### 4. Conclusion

In Table 1 and Fig. 6, baroswitch calibration charts, as acquired by the digital calibration system and the previous analog type system respectively are shown. Since it was not feasible to reproduce the exact analog type calibration chart, a faithful amplified tracing has been presented. In case of analog type calibration chart, the manual decoding of pressure values has evident inherent errors, especially at lower pressures, shown in the later part of Fig. 6, where the number of contacts are more in a small pressure range and smudging of contacts results in greater decoding errors. The errors in pressure values at lower pressure ranges were of more significance for both temperature and gpm values, as deduced by radiosonde measurements. All these weaknesses have been taken care of by digital calibration which provides direct read out and hence human judgement is completely eliminated. This has also improved resolution and accuracy. The digitally calibrated baroswitches have been introduced in the national upper air network since 1990 and the performance of the system has been found satisfactory. It is planned, in future, to obtain these charts in the form of perforated tapes for direct feeding into the computer system which will further reduce the time taken by operator to feed the calibration chart in the computer through keyboard.

### Acknowledgements

The authors are grateful to Dr. S.M. Kulshrestha, Director General of Meteorology for guidance and encouragement. Thanks are also due to the colleagues of Upper Air Laboratory, Office of the Dy. Director General of Meteorology (Upper Air Instruments) for their co-operation in successful completion of the project.