

Forecasting of rainfall of 30 mm or more over Bombay

HEM RAJ and H.S. BILLA

Institute of Tropical Meteorology, Poona

(Received 8 July 1965)

ABSTRACT. The graphical integration technique of Brier has been employed in evolving an objective method for predicting the occurrence of rainfall of 30 mm or more in 24 hours over Bombay and Thana Districts, in the subsequent 24 hours, during July—August. Easily determinable variables—(1) 700-mb contour height difference between Calcutta and Visakhapatnam, (2) 850-mb contour height difference between Nagpur and Delhi, (3) surface pressure difference between Vengurla and Baroda and (4) precipitable water over Bombay, have been utilised in evolving this technique. Data for the months of July and August for 1957-1961 have been used as basic data and corresponding ones for 1962 as the test data. The method gave correct forecasts of rainfall ≥ 30 mm on 70 per cent occasions.

1. Introduction

Heavy rainfall is of great importance to many industrial, agricultural, flood control, military operations, etc. As the time lag between heavy rainfall and the consequent damage to such operations may not afford sufficient time for taking preventive measures, it would be greatly advantageous to know the occurrence of heavy rainfall at least within subsequent 24 hours. The problem of predicting when and how much precipitation will occur over a specified small area is being posed to the forecaster very frequently. However, even though a lot of work has been done on the mechanism and seasonal aspects of rainfall over India, very little has been done on the forecasting aspect of heavy rainfall over small areas. The present paper is an attempt in this direction.

2. Selection of approach

It is desirable that any attempt at developing a method for forecasting heavy rainfall is as objective as possible. In a search for any objective method two approaches are possible—(i) Physical and (ii) Statistical.

The statistical technique employed in this study is that adopted by Brier (1946) and termed as "Graphical Integration Technique". Essentially this technique consists in relating the occurrence and amount of rainfall to a number of meteorological variables which are independent of one another. The chosen variables are then grouped in pairs and used as co-ordinates of a scatter diagram on which the amount of rainfall is plotted. The analysis is carried out by constructing isograms of rainfall amount on each chart to evaluate a derived parameter. The derived parameter resulting from each pair of variables are again combined in pairs and the process repeated until finally only one forecasting parameter W remains. This final derived parameter is thus a function of all the original variables. The scheme is illustrated here.

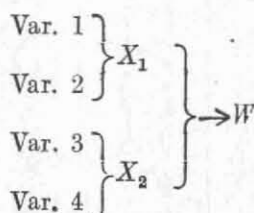

The graphical technique has the disadvantage of a certain amount of subjectivity in the original combination of variables. However, this is largely outweighed by its relative simplicity. It also eliminates the necessity for having a prior knowledge of, or making assumptions regarding, the functional relationship between the independent variables and the dependent variate, a requirement common to all mathematical regression methods.

3. Problem and data

The present paper is an attempt to forecast rainfall of 30 mm or more over Bombay and Thana districts in the subsequent 24 hours during the southwest monsoon period. An average rainfall of 30 mm or above over 15 raingauge stations in this area of 3800 sq. miles is used. For the purpose of this paper the study has been confined to the months of July and August. At first it was intended to include the study for the months of June and September but it had to be abandoned as useful results could not be obtained with them.

The data used in the development of the objective procedures were taken from 0000 GMT (0530 IST) radiosonde ascents of Bombay, Delhi, Calcutta, Visakhapatnam and Nagpur and 0300 GMT surface pressure of Vengurla and Baroda for the months of July and August for the years 1957-61. Data from 280 cases during the period were used in the study to derive the relations. These are termed as 'dependent' or 'original' data. Data for the same months of 1962 comprising 59 cases were used to test the procedures. These are termed as

'independent' or 'test' data.

4. Selection of variables

A large number of meteorological variables which were believed to be of significance in forecasting rainfall over this area were tested both singly and in various combinations. Of the relationship tested the following produced the greatest skill and were incorporated in the final forecasting method. Though it is difficult to fully reason out the selection of these parameters, the main reason of their choice is indicated against each.

(a) 700-mb height difference between Calcutta and Visakhapatnam indicates presence of any disturbance over the north Bay of Bengal.

(b) 850-mb height difference between Nagpur and Delhi provides a rough measure of the pattern and strength of the wind flow across central parts of the country.

(c) Surface pressure difference between Vengurla and Baroda indicates strength of the monsoon current over the west coast at lower levels.

(d) Precipitable water over Bombay from surface to 500-mb level provides a suitable yardstick for the amount of moisture available over the area.

These four variables were combined graphically according to the following diagram—

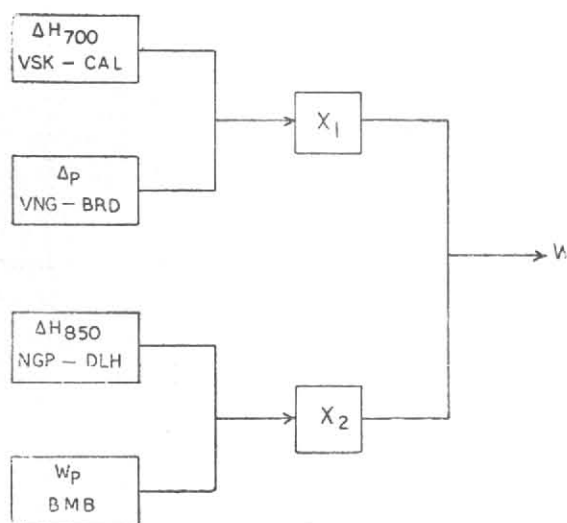

VSK—Visakhapatnam, CAL—Calcutta, VNG—Vengurla
BRD—Baroda, NGP—Nagpur, DLH—Delhi, BOM—Bombay

The first three parameters were obtained from surface and upper air observations and the fourth parameter, the precipitable water W_p upto 500-mb was computed from radiosonde observations.

$$W_p = 0.1 [r_s + 2(r_{800} + r_{600})]$$

where,

r_s = Humidity mixing ratio at surface

r_{800} = Humidity mixing ratio at 800-mb level

r_{600} = Humidity mixing ratio at 600-mb level

In the above formula, r_s , r_{800} and r_{600} are taken to represent the average moisture conditions of layers from surface to 900, 900-700 and 700-500 mb respectively. Even though W_p thus calculated may not be accurate, it was considered to be representative for this study.

5. Technique

The scatter diagram shown in Fig. 1 was prepared by plotting 700-mb height difference between Visakhapatnam and Calcutta as abscissa against surface pressure between Vengurla and Baroda as ordinate. For each day a plotted circle indicated occurrence of rainfall of 30 mm or more and a dot indicated rainfall amounts below 30 mm during the next 24-hor period, *i.e.*, 0830 IST of date to 0830 IST of the following day. The isograms of rainfall adjusted to a scale of 1 to 10 were drawn. These lines define a single variable X_1 .

Fig. 2 is the scatter diagram prepared on the above lines by plotting 850-mb height difference between NGP and DLH as abscissa against precipitable water W_p over Bombay from surface to 500-mb level as ordinate. The isolines on this diagram define the derived parameter X_2 .

The derived parameters from these two scatter diagrams were then combined into the final diagram shown in Fig. 3. A "forecast" line W was drawn on this combined diagram to separate out the days of rainfall ≥ 30 mm from other days. Any point falling to the right of this line will be forecast as a day with rainfall ≥ 30 mm. Lines B, C, and D on this diagram represent a confidence of 70, 80 and 90 per cent respectively. However, a forecaster may have to call upon his judgement and experience in weighing and giving the final forecast for a point that falls between A and W lines. Such cases, of course, are rare, only 2 or 3 in a year.

6. Results

Out of 280 days of original data there are 104 days when average rainfall over 15 raingauge stations in the area under study was 30 mm or above and in the remaining 176 days rainfall was less than 30 mm. These results are summarised in Table 1.

From Table 1 it may be seen that on 75 out of the 104 occasions of rainfall ≥ 30 mm could be correctly forecast. This gives a correct percentage of 70 per cent.

This forecasting scheme was tested on independent data (July and August 1962). The results as shown in Table 2 were obtained. In this case 12 out of 17 cases of rainfall ≥ 30 mm, *i.e.*, 71 per cent, could be correctly forecast.

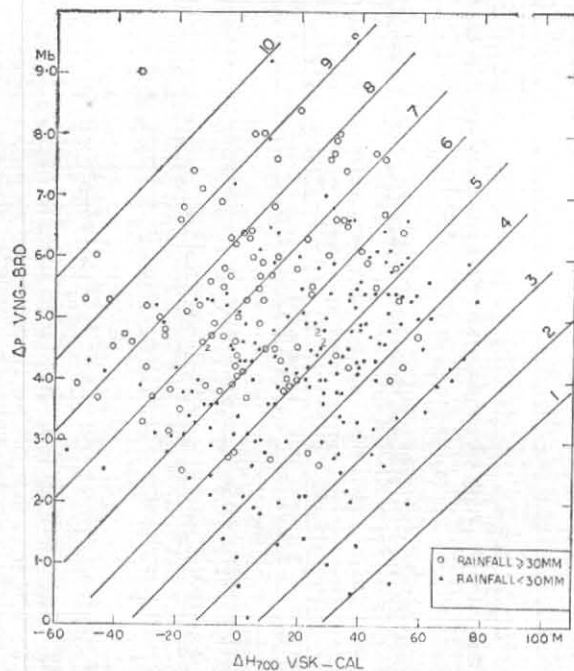

Fig. 1. Scatter diagram showing rainfall over Bombay as a function of ΔH_{700} VSK-CAL and ΔP VNG-BRD

Isograms of occurrence of heavy rainfall adjusted to a scale of 1 to 10 are drawn. These isolines define a derived variable X_1

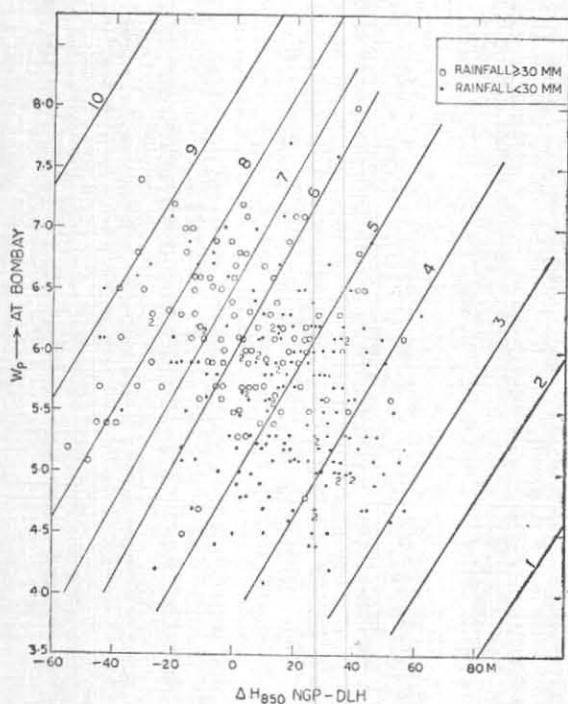

Fig. 2. Scatter diagram showing rainfall over Bombay as a function of ΔH_{850} NGP-DLH and W_p (precipitable water) over Bombay

The isolines define a derived variable,

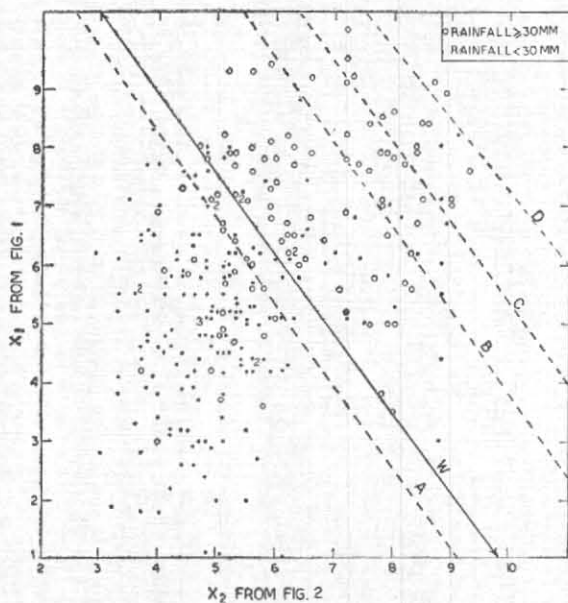

Fig. 3. Forecast diagram combining the derived variables X_1 from Fig. 1 and X_2 from Fig. 2

The line W separates the cases of ≥ 30 mm. Lines B, C and D represent confidence of 70, 80 and 90 per cent respectively X_2

TABLE 1

Contingency table showing results of "forecast" by applying the forecasting technique to 280 cases of original data (1957-61)

	Objective forecast		
	<30 mm	≥30 mm	Total
Observed			
<30 mm	143	33	176
≥30 mm	28	76	104
Total	171	109	280

Correct percentage forecast for rainfall 30 mm or more = $(76/104) \times 100 = 70$ per cent

7. Conclusion

This investigation shows that rainfall over small areas can be forecast by a systematic utilization of readily available parameters. The method evolved here is not a substitute for present day forecast techniques, but may serve as an aid to the forecaster. However, he must still use his experience to arrive at the final forecast, as such subjective rules or aids cannot, in general, accurately indicate

Annanthakrishnan, R., Selvam, M. M.
and Challappa, R.
Brier, G. W.

TABLE 2

Contingency table showing results of "forecast" by applying the forecasting technique to 59 cases of test data (1962)

	Objective forecast		
	<30 mm	≥30 mm	Total
Observed			
<30 mm	37	5	42
≥30 mm	5	12	17
Total	42	17	59

Correct percentage forecast for rainfall 30 mm or more = $(12/17) \times 100 = 71$ per cent

the relative weight to be applied to the different meteorological variables. By the adoption of this technique there appears to be a possibility of reducing the cases of over-warning.

8. Acknowledgements

The authors are grateful to Dr. K.R. Saha for his valuable suggestions and kind and sustained interest throughout the study.

REFERENCES

- 1964 Res. Pap., 12, Poona.
1946 U.S. Weather Bureau Res. Pap. 26,
Washington D.C., p. 40.