

A new dew-point hygrometer

N. R. GOKHALE and K. M. GATHA

Physics Department, Institute of Science, Bombay

(Received 22 May 1958)

ABSTRACT. A new form of dew-point hygrometer has been developed to measure accurately the relative humidity of air inside small chambers. Its construction, assembly inside Millikan's oil-drop apparatus and operation have been described. Its comparative merits have been discussed.

1. Introduction

It is well-known that Cloud Physics is an important branch of study in meteorology. The physics of the cloud requires information about the rate of evaporation of water droplets. Millikan's oil-drop apparatus has been found quite suitable for observing such evaporation. However, the chamber of such an apparatus is usually very small. Therefore the usual types of hygrometers are unsuitable for measuring the relative humidity of air inside such a small chamber.

In studying the rate of evaporation of unattached water droplets in Millikan's oil-drop apparatus the experimental determination of relative humidity of the air inside the chamber, after the spraying operation, has also presented considerable difficulties. A device to measure accurately the relative humidity of the air inside a small chamber, such as that of Millikan's oil-drop apparatus, was needed. This problem has been solved by developing a new type of dew-point hygrometer.

2. The new dew-point hygrometer

This hygrometer consists of a narrow silver tube, which is 8.5 cm long and 0.3 cm in diameter, with one end bent as shown in Fig. 1. The straight end is inserted in the glass container for ethyl ether. The diameter and the height of the cylindrical glass container are $1\frac{1}{4}$ inches and 7 inches respectively. This container has two openings, one at the top and the other at its side. Both the openings are closed with the help of ordinary

corks. Rubber corks are not suitable for this purpose as ethyl ether reacts with rubber. The bent glass tubes are inserted through the cork at the top as shown in Fig. 1. One tube acts as an inlet for the air which is forced by a 'Cenco' presso-vac pump. The air bubbles through ethyl ether in the glass container and leaves through the second tube. This tube is sufficiently long to carry away the liquid vapour from the neighbourhood of Millikan's apparatus. The flow is adjusted with the help of a stop-cock as shown in Fig. 1. By adjusting the air flow in this manner, it is possible to cool ethyl ether in the glass container to the desired low temperature. Solid carbon dioxide, placed outside the glass container, helps to cool the liquid to still lower temperatures, if necessary.

The cooled ethyl ether is allowed to flow through the silver tube and the liquid is carried away by another tubing attached to the bent end of the silver tube as shown in Fig. 1. With the help of the pinch cock, it is possible to regulate the liquid flow and thereby cool the silver tube to the desired low temperature.

Only a small portion of the surface of the silver tube is kept uncovered and the dew formation is noted on it. The remaining surface of the tube is covered with a rubber tubing of very low thermal conductivity. Hence with this arrangement, only the small exposed portion of the silver tube cools to a sufficiently low temperature to allow the dew formation, while the surfaces of the

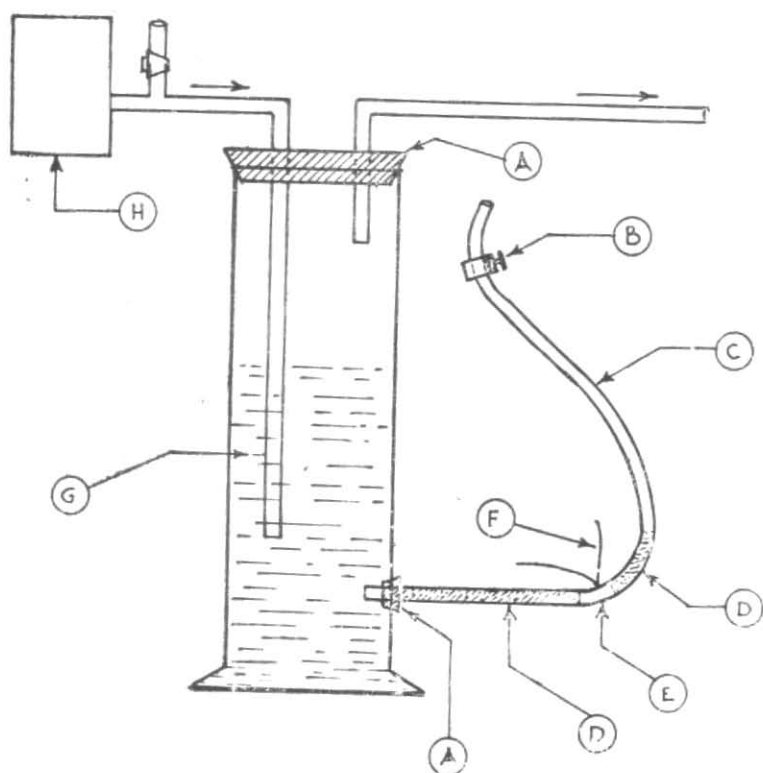

Fig. 1. New Dew-point Hygrometer

A—Cork
 B—Pinch cock
 C—Tube for carrying away ether
 D—Silver tube covered with rubber tubing

E—Portion of the silver tube where dew formation is observed
 F—Thermocouple
 G—Ethyl ether
 H—Pump

rubber tubes are not cooled to that temperature and hence no dew forms there. This arrangement is necessary as the quantity of water vapour inside the small chamber of Millikan's oil-drop apparatus should be able to form sufficient dew for detection. If the entire surface of the silver tube is exposed to the air inside the chamber, the dew detection would be very difficult. The dew formation on this small surface is observed through a telemicroscope as described later. The temperature of this surface where dew forms is accurately noted with the help of a thermocouple, attached exactly on the back of this surface.

3. Assembly inside Millikan's apparatus

The surface of the silver tube, with the thermocouple attached, is covered with two rubber tubings. Only a small portion is kept uncovered as shown in Fig. 1. One more tube to carry away the ether is attached to the bent end of the silver tube. Then the silver tube, with all its attachments, is placed inside the chamber of Millikan's apparatus after removing the top brass plate. Two wires of the thermocouple and the outlet tubing are taken out through a cork fixed in a hole at the side of the apparatus as indicated in Fig. 2. The other end of the silver tube, which is straight,

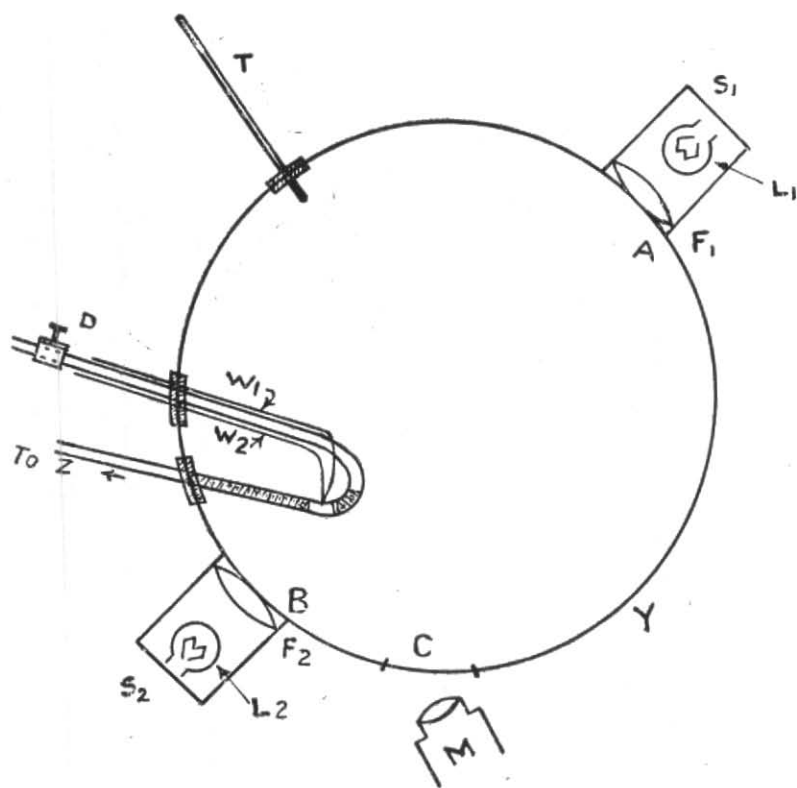

Fig. 2. Arrangement in Millikan's Oil-drop Apparatus

A, B, C—Glass windows
 L₁, L₂—Lamps
 S₁, S₂—Screens
 F₁, F₂—Biconvex lenses
 D—Pinch cock

Y—Chamber of Millikan's Oil-drop Apparatus
 T—Thermometer
 M—Tele-microscope
 W₁, W₂—Thermocouple wires
 Z—Glass container for ethyl ether

is pushed out through a cork fixed in another hole in the side of the apparatus. This end of the silver tube is then pushed further through a hole in the cork, fitted to the side of the glass container, so as to reach the liquid ethyl ether. The silver tube was made to fit in the cork very tight in order to avoid leakage of ethyl ether.

4. Operation of the new hygrometer

One may now consider the working of this new dew-point hygrometer. Air, forced by the presso-vac pump bubbles through ethyl ether

and cools it to the desired low temperature. When this pre-cooled liquid is allowed to flow through the silver tube, the exposed small portion of this tube cools down sufficiently to allow dew formation on it. The dew formation is noted with the help of the tele-microscope and the lighting arrangement as shown in Fig. 2. As already stated, the temperature of the surface is noted accurately with the help of the thermocouple.

The lighting arrangement consists of a pigmy type 15 watt lamp marked L₂ in Fig 2.

The biconvex lens which is fixed to the window B, with the help of wax, condenses the light from lamp L_2 on to the portion of the silver tube, where dew formation is to be noted. Screen S_2 avoids the light of the lamp L_2 falling on the objective of the telemicroscope. The telemicroscope is focussed on the part of the tube illuminated by the condensed light. With this arrangement it is easy to detect the first traces of dew formation, without any appreciable skill.

5. Comparative merits of the new hygrometer

One may now see how the disadvantages of the dew-point hygrometers are overcome by this new form of such a hygrometer. Firstly, the need of some special skill to detect the first traces of dew formation is eliminated by the lighting arrangement and viewing the dew formation on the surface by means of a telemicroscope. Secondly, the usual uncertainty arising from the temperature of ethyl ether being different from the temperature of the surface for dew formation is overcome by determining accurately the

temperature of the surface with the help of the thermocouple, attached to the back of this very surface. Hence, the measurement of the temperature of ethyl ether is quite unnecessary. Further, a suitable method for cooling ethyl ether is devised, as described earlier, with the help of the controlled air-flow produced by the presso-vac pump. It avoids the tiresome old method to cool the liquid with the help of a hand blower. The required low temperature of the liquid can now be obtained within about 5 minutes. Furthermore, by exposing only a small portion of the silver tube to the air inside the chamber dew formation, sufficient for detection, is easily produced by the water vapour in the air inside the small chamber.

The accuracy in determining the value of relative humidity with this new form of dew-point hygrometer, is estimated as ± 0.01 . Thus this new dew-point hygrometer is quite suitable for very accurate determination of the relative humidity of air inside a very small chamber such as that of Millikan's oil-drop apparatus.
