

A standard multi-pulse generator for calibration of radiosonde recorders

B. BHARGAVA

Project Scientist's Unit, Trivandrum

(Received 29 May 1971)

ABSTRACT. The paper describes an instrument designed to calibrate IMD A-type radiosonde recorders. A unique and extremely simple technique of adding pulses derived from binaries in cascade has been employed to provide spot check frequencies in the audio range.

1. Introduction

An audio-modulated radiosonde developed in the departmental laboratories and workshops at New Delhi has now been introduced at the upper air observatories of the India Meteorological Department, replacing the chronometric and fan type radiosondes. The meteorological data in the new IMD radiosonde are recorded in the form of pulses varying over the range 0-200 cycles per second and are transmitted through a miniature UHF transmitter. At the ground station the received signals are converted into D.C. voltages in a frequency converter and applied to the measuring circuit of a strip chart recorder. The accuracy of the radiosonde data depends, besides other factors, on the accuracy of the recording. A check on the performance of the recording system is, therefore, necessary and is maintained by periodically calibrating the equipment. The arrangement for the calibration of the recorder is illustrated in Fig. 1. Spot frequencies from the standard generator are fed to the recording system and are traced on the graduated recorder chart paper. This record of the output pulses is the calibration record for the particular frequency-converter-recorder combination. Correction table and correction graph are then prepared from the calibration record for the various frequencies recorded by the recorder and applied to the radiosonde flight records during computation to obtain the corrected data.

The multi-pulse generator described in this paper was specifically designed to provide suitable check frequencies for calibrating the IMD audio modulated radiosonde recorders.

2. Principle

The radiosonde data signals appear as audio frequencies at the input of the frequency converter. The frequency converter consists of a pulse

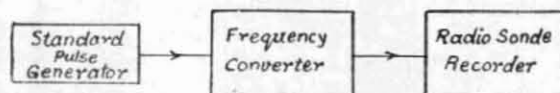

Fig. 1

Schematic diagram — Calibration system

generator, driver, amplifier and wave shaper which feeds square wave signals to a magnetometer driver. The audio signal pulses are thus converted to proper amplitude and shape, rectified and filtered to provide a D.C. voltage proportional to the frequency of the input signal. This D.C. voltage which is obtained from D.C. pulses of equal magnitude is applied to the recorder. The non-uniformity in the frequency of signals at the input of the frequency converter would not be of any consequence, as each individual pulse is suitably converted into a corresponding analogue output. The radiosonde recorder is a strip chart rectilinear recorder operating on the null balancing principle.

The radiosonde signals are recorded in the frequency range of 0-200 cycles per second. The accuracy of recording of the frequencies in this range is required to be ± 0.2 cps which is the reading accuracy on the recorder chart. It is desirable that the accuracy of the source used for calibrating the recorder be one order better, i.e., its accuracy should be ± 0.02 cps. For the same percentage accuracy, the maximum error in cps is at the maximum recordable frequency, which is 200 cps. The error of 0.02 cps at 200 cps corresponds to an accuracy of 0.01 per cent. The accuracy required for a 10 kc source, is, therefore, ± 1 cycle. A crystal oscillator is used as the source in the standard generator described in this paper.

The spot frequencies required to be derived with the above accuracy in the output of the standard pulse generator for proper calibration of the recorder are 10, 20, 40, 60, 80, 100, 120, 140, 160

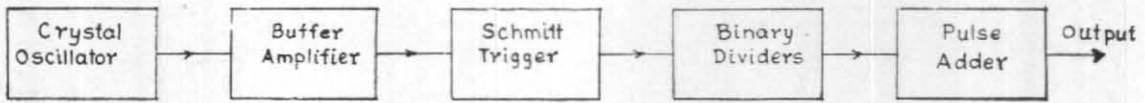
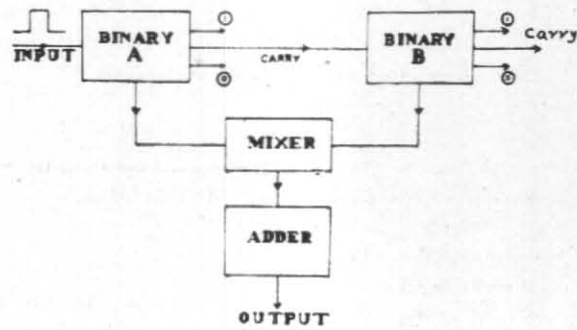
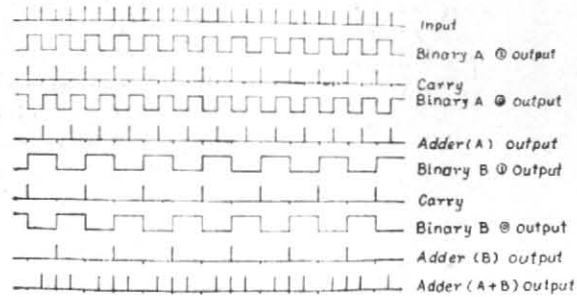

Fig. 2

Block diagram—Standard multi-pulse generator



(a) BLOCK DIAGRAM



(b) ON-OFF DIAGRAM

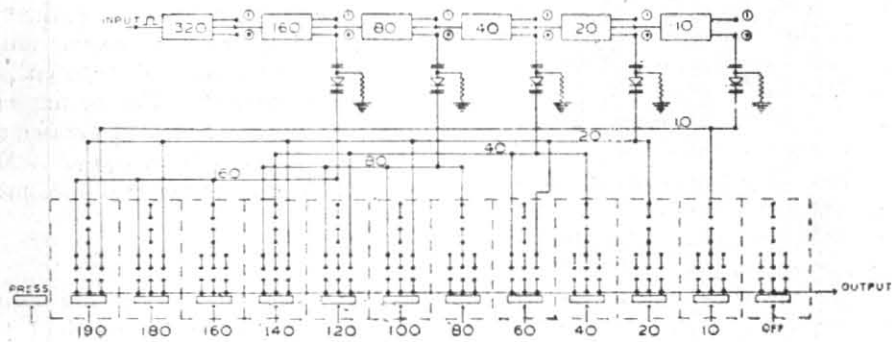

(c) Mixer circuit

Fig. 3 Pulse adder

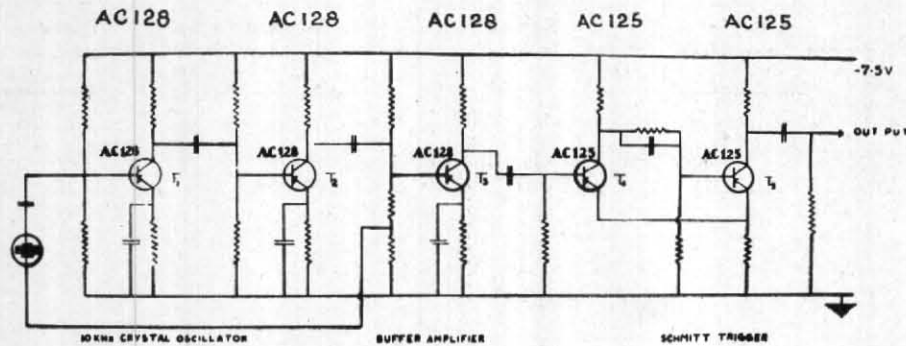

Fig. 4

Circuit diagram ~ Crystal oscillator

180 and 190. The arrangement employed in the present instrument to obtain these outputs is illustrated in the block diagram in Fig. 2. Binary dividers are used to obtain 320 pps from the 10 kc crystal oscillator, this is done in three stages consisting of three binaries each. In the first stage the 10 kc input is divided by 5 to obtain 2 kc output. In the second stage the 2 kc input is divided by $5/2$ to obtain 800 pps which are again divided in a similar third stage by $5/2$, to get an output of 320 pps. Simple binary division of 320 pps leads to the primary check frequencies of 160, 80, 40, 20 and 10 pps in the output of the standard pulse generator. The rest of the desired output frequencies are obtained by additions employing a unique and extremely simple technique explained in Fig. 3(a). The outputs of the two binaries A and B in cascade form the outputs (A) and (B) of the adder individually and the output (A+B) in combination. Normally, the output pulses from the two binaries cannot be added together as the output pulses of the binary B are synchronous to the alternate output pulses of binary A. However, if the pulses are taken from the collectors of the input sections of the binaries, shown as (0) outputs in the on-off diagram in Fig. 3(b), the pulses from binary B fall midway between the pulses from binary A and can be added together as illustrated in the diagram. This diagram also shows that the pulses when added together are not uniformly spaced throughout; however as explained earlier, this non-uniformity in the periodicity of the pulses is of no consequence for the particular application for which the pulse generator has been designed. The check frequencies of 190, 180, 140, 120, 100, and 60 pps are thus obtained in the output of the pulse generator by simple additions of the various primary check frequencies as illustrated in Fig. 3(c). Only positive pulses obtained on differentiation of the square wave binary output are fed to the mixer and are isolated from the other binaries in the simple arrangement shown. The accuracy of all the check

frequencies is maintained because of the digital process employed.

3. Circuits

The circuit diagram of the crystal oscillator is illustrated in Fig. 4. The 10 kc oscillator consists of transistors T_1 and T_2 . Part of the output of T_2 which is the second stage of amplification is fed back through the crystal to the input of T_1 , the first stage, so that the desired stability is obtained. The oscillator is isolated from the load by the buffer amplifier comprising of transistor T_3 so that both the amplitude and stability of the oscillator output are not disturbed during the operation and use of the pulse generator. The Schmitt trigger circuit consisting of transistors T_4 and T_5 converts the output of the oscillator to square waves which on differentiation by the RC circuit provides suitable pulses to be fed to the binary dividers.

Fig. 5(a) illustrates how division by five is achieved through feedback from three binaries in cascade. The states of the output collectors of the three binaries for various pulses applied to the input of the binary B_1 are illustrated in Fig. 5(b). As shown in the diagram, for an input of five pulses at the binary B_1 , there is an output of one pulse either from the binary B_2 or the binary B_3 , while there are two pulses in the output of the binary B_1 . Division either by 5 or by $5/2$ has thus been effected. It may of course be noticed that the periodicity of pulses from the output of B_1 is not uniform, which, in the present case, is not important.

4. Description

The standard multi-pulse generator illustrated in Fig. 6 is a portable instrument as it is meant to be supplied to each of the radiosonde observatories of the India Meteorological Department. It operates from a 9 volt commercially available power pack, which is built-in. The instrument utilises

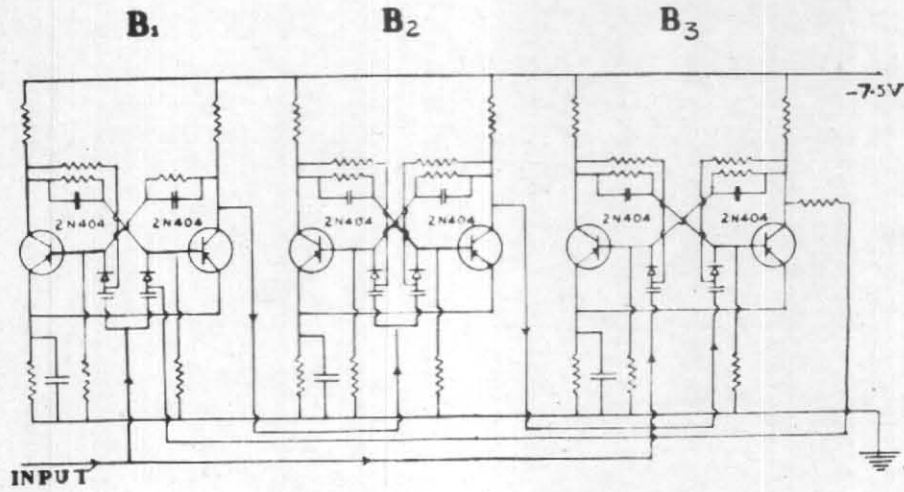

(a) Circuit diagram

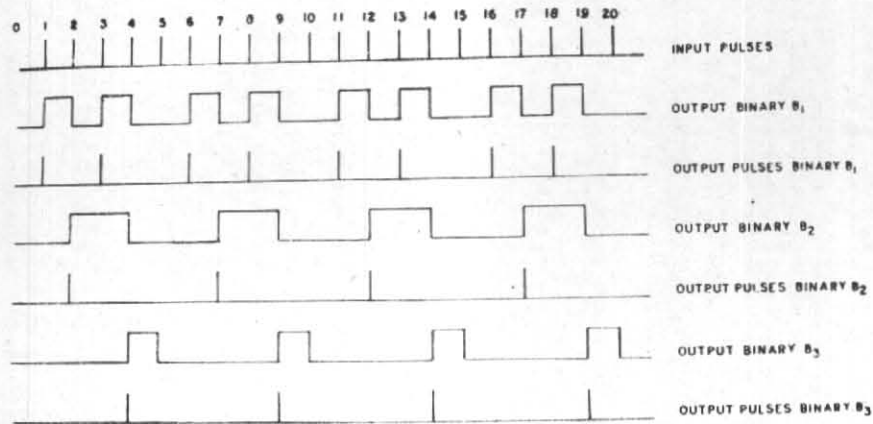

(b) Binary outputs

Fig. 5. Binary division by 5 and 5/2

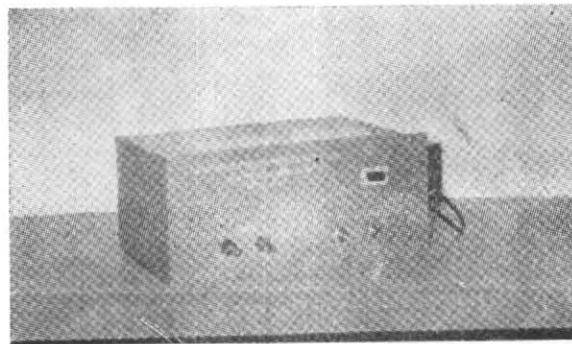

Fig. 6. Standard multi-pulse generator

only low cost indigenous components. Printed circuit cards are used in the pulse generator and are mounted in such a way that they are easily replaceable. Three pole spring driven band switches are required in this instrument for effecting additions of pulses to obtain the desired output

frequencies from the generator. Such switches used in commercial radiosets were available with a maximum of six piano type push button keys. Two of these switches were mechanically coupled together to obtain the twelve outputs, including the OFF position, from the generator.

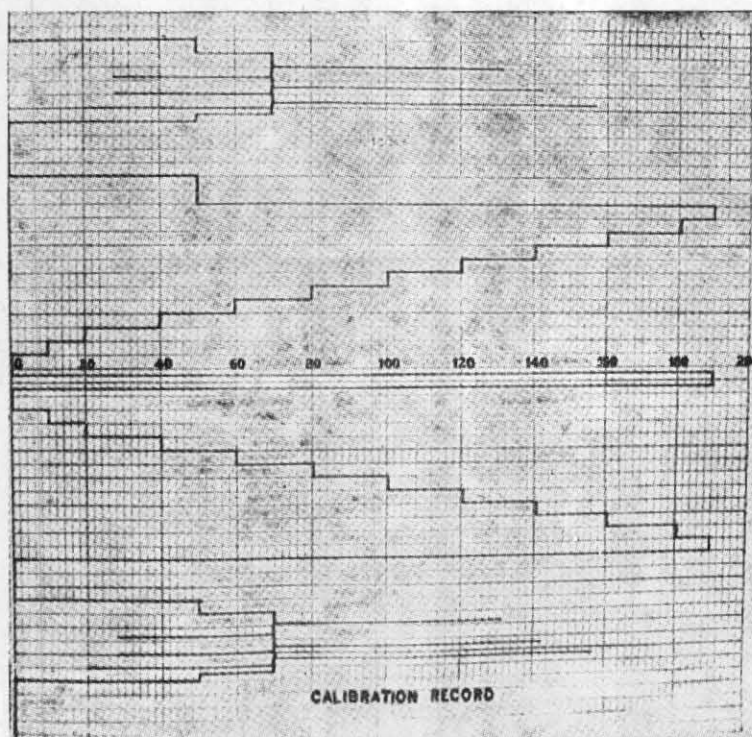

Fig. 7. Calibration record

5. Performance

The pulse generators have been supplied to a number of radiosonde stations of the India Meteorological Department, where they have now been in routine use for about two years. A sample of the calibration record obtained during the routine check on the performance of a radiosonde recorder is given in Fig. 7.

Acknowledgements

The author is grateful to Shri M. L. Vadhera and Shri N. P. Jauhari for their help in assembling the various units. Thanks are also due to all the other colleagues in the Laboratories and Workshops of the Meteorological Office, New Delhi for their co-operation.

The work reported in this paper has earned a Shield for the India Meteorological Department and an Award of Rs. 2000.00 for Shri B. Bhargava announced by the Invention Promotion Board, Govt of India on the Republic Day 1973 for meritorious inventions and import substitutes.