

The dependence of long-wave radiation on cloudiness, water vapour content and temperature

R. R. KELKAR and R. V. GODBOLE

Institute of Tropical Meteorology, Poona

(Received 30 October 1969)

ABSTRACT. Long-wave radiative heat fluxes and cooling rates have been computed for a model atmosphere representing mean conditions over the Indian region during the monsoon season. Variations in the values of flux and cooling rate for given deviations from the model atmosphere have been studied. The individual contributions of cloudiness, water vapour content and temperature to the radiative processes have been assessed separately.

It is found that a change in the cloud amount causes large changes in the cooling rate near the top and base of the cloud, but does not significantly alter the integrated cooling of the atmospheric column. The integrated cooling, however, increases with a decrease in the height of the top or base. The upward flux at any level is strongly controlled by the surface temperature, whereas the downward flux is largely dependent on the water vapour content above the level.

1. Introduction

In an earlier work (Godbole and Kelkar, 1969), the authors described a numerical method for the computation of long-wave radiative heat fluxes at the earth's surface and at standard isobaric levels in the atmosphere, based upon the atmospheric radiation tables of Elsasser and Culbertson (1960). In the present study, the same method has been applied to compute the long-wave radiative heat fluxes and cooling rates for a "model atmosphere" which represents mean conditions over the Indian region during the monsoon season. The values of flux and cooling rate were also computed for given deviations from the model atmosphere. The study has a two-fold objective— (i) to understand the manner in which parameters like cloudiness, temperature and dew-point individually influence the radiative heat exchange processes, and (ii) to estimate the extent to which errors in the observations of these parameters affect the final computed results.

2. The Model Atmosphere

The model atmosphere is defined in columns 1-3 of Table 1. It has been derived as the arithmetic mean of the 1951-65 normals* of upper air temperature and dew-point for the period of four months, June to September, for the 18 Indian radiosonde stations, in so far as all the upper levels are concerned. However, for the surface, the mean atmospheric pressure and temperature were obtained

from the 1931-60 normals† for 220 stations in India for the period June to September, and the dewpoint was derived from the normals of wet bulb temperature for the same stations and months. The mean height of the 220 stations considered is 336 m above sea level and the mean value of the surface pressure reduced to sea level is 1002 mb.

The mean cloud amount for the monsoon season was determined from the 1931-60 normals as available for the 220 stations. The height of the base of the cloud layer was fixed at the 875-mb level corresponding to the height of 4,000 ft obtained by Rao (1955). Godbole and Kelkar (1969) considered the top of the cloud in the monsoon period to be at 400 mb (25,000 ft) or 200 mb (41,500 ft) depending upon whether the cloud was of the medium or high type. An examination of the day-to-day cloud observations in the monsoon season revealed that the probability of a high cloud being reported on any day was, on an average, about 50 per cent. On this basis, the top of the cloud layer in the model atmosphere was fixed at the mean height of 33,250 ft corresponding to the 275-mb level.

The values of the long-wave radiative flux and cooling rate computed for the model atmosphere are given in Table 1. Comparison with the values of flux and cooling rate observed by Mani *et al.* (1965) for Poona during the monsoon period shows good agreement.

*Normals of Climat Temp based on Morning and Afternoon/Evening Radiosonde Data for the period 1951-65, India met. Dep.

†Climatological Tables of Observatories in India (1931-60), India met. Dep.

TABLE 1
The Model Atmosphere

Pressure (mb)	Temperature (°C)	Dew point (°C)	Optical depth w.r.t. surface (gm/cm ²)	Flux (ly/day)			Rate of temp. change (°C/day)
				Upward	Down- ward	Net	
966 (Surface)	28.1	22.9	0.00	961.6	842.4	119.2	
950	27.2	22.0	0.29	957.3	832.6	124.7	— 1.43
900	24.0	19.0	1.07	937.4	802.1	135.3	— 0.86
850	20.6	15.6	1.72	882.3	767.9	114.4	+ 1.71
800	17.7	12.5	2.24	852.5	731.6	120.9	— 0.53
750	14.5	9.0	2.66	826.8	693.5	127.3	— 0.53
700	11.6	5.5	2.99	792.9	660.4	132.5	— 0.42
650	8.3	2.7	3.26	762.6	625.1	137.5	— 0.42
600	4.5	—0.2	3.47	729.4	587.4	142.0	— 0.36
550	0.8	—3.5	3.65	698.2	552.3	145.9	— 0.32
500	— 3.5	—7.0	3.78	664.3	514.2	150.1	— 0.33
450	— 8.5	—	3.88	627.0	474.0	153.0	— 0.24
400	—13.5	—	3.95	592.2	436.3	155.9	— 0.23
350	—20.0	—	4.01	550.3	391.9	158.4	— 0.21
300	—27.0	—	4.05	509.0	348.2	160.8	— 0.19
250	—36.4	—	4.08	476.5	123.3	353.2	—15.75
200	—47.6	—	4.11	460.4	97.2	363.2	— 0.81
150	—61.0	—	4.13	443.4	72.6	370.8	— 0.62
100	—72.2	—	4.14				

Integrated cooling : 1.26 °C/day

3. The effect of cloud

Cloud amount — Keeping the heights of the base and top of the cloud fixed as in the model atmosphere, the cloud amount was varied in steps of 2 octas. The vertical distributions of cooling or heating rate as obtained in each case are plotted in Fig. 1.

For cloud amount zero, *i.e.*, clear sky, there is a cooling at all the levels in the atmosphere, the highest value being 3.4°C/day in the layer between the surface and 950 mb, and then gradually decreasing upwards. As the cloud amount increases, the cooling near the cloud top becomes more and more prominent, the maximum of 21.9°C/day being reached for an overcast sky. On the other hand, near the base, the cooling of 2.0°C/day noticed in the case of a clear sky becomes progressively smaller as the cloud amount increases, ultimately changing sign and leading to a moderately large amount of heating, 3.2°C/day, when the sky is overcast. Within the interior of the cloud, the effect of variation in the cloud amount is found to be comparatively small, *e.g.*, at 675 mb the cooling is zero for

overcast sky and only 1.45°C/day for clear sky. Also, above the cloud top, the cooling rate depends very little on the changes in the cloud amount considered. The net or integrated cooling when computed for the atmospheric column as a whole, is not found to be significantly affected by the changes in the cloud amount. The range of variation noticed is only between 1.264°C/day for clear sky and 1.259°C/day for an overcast sky.

Height of cloud base — The effect of varying the thickness of the cloud was studied by fixing the base (top) of the cloud at different heights, keeping the cloud amount and the height of the top (base) as in the model atmosphere. Since the cloud is considered to be a black body, the net flux at any level below the cloud base is largely determined by the downward black-body flux from the cloud base. The lower the base, the higher is its temperature and consequently the downward flux is more. On the contrary, the net flux becomes smaller since the upward flux at any level below the base of the cloud remains unchanged. For example, the net flux at the ground surface which had a value of

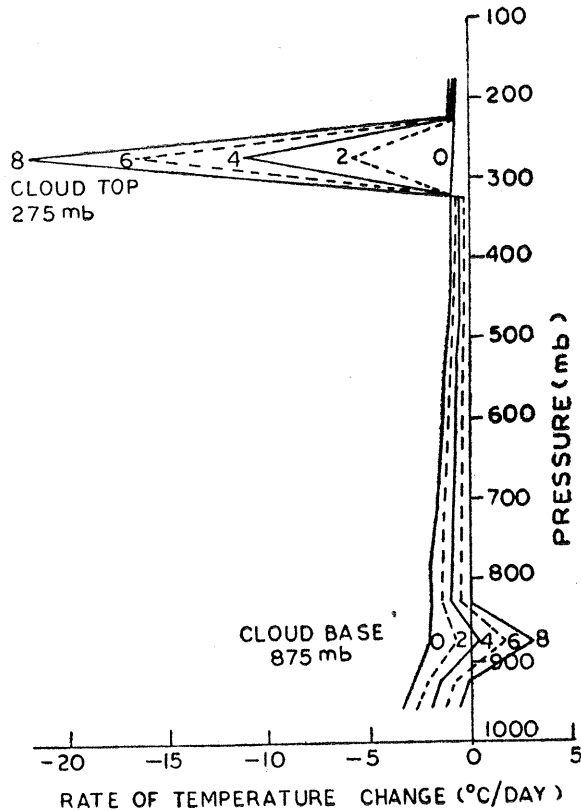

Fig. 1. Vertical profile of the rate of temperature change for various cloud amounts (0, 2, 4, 6 & 8 octas)

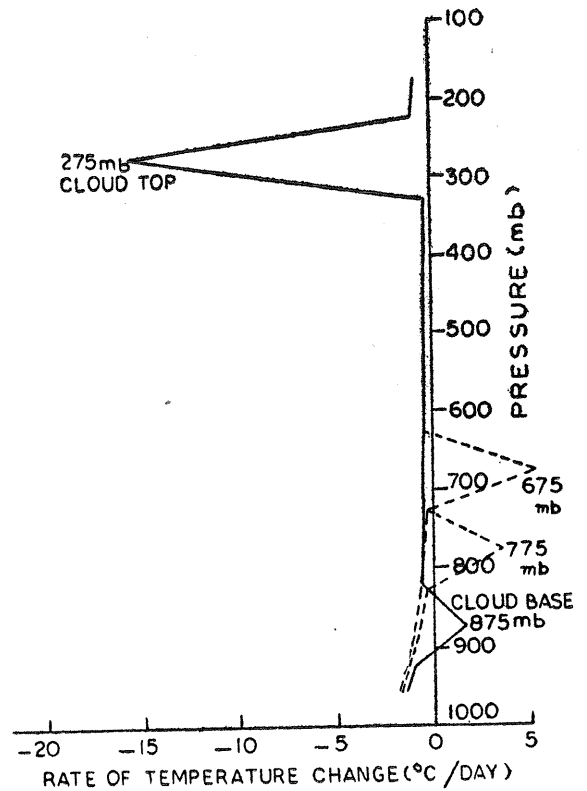

Fig. 2. Vertical profile of the rate of temperature change for various heights of the cloud base

155 ly/day when the base of the cloud was considered at 675 mb, was found to be 119 ly/day when the base was lowered to 875 mb, corresponding to a decrease of the net flux by 23 per cent.

The effect of varying the height of the cloud base upon the vertical distribution of temperature change is shown in Fig. 2. The height at which the maximum heating occurs is clearly seen to decrease with a reduction in the cloud base height. Further, the magnitude of the heating below the cloud base is also seen to decrease as the base shifts downward. The integrated cooling increased only from 1.08°C/day for the cloud base at 675 mb to 1.26°C/day for the cloud base at 875 mb, or by 17 per cent.

Height of cloud top—The situation is reversed when the height of the cloud top is changed keeping the base fixed as in the model atmosphere. If the cloud top is shifted downward, its temperature rises and the upward black-body emission increases, so that the net flux at a level above the top increases. At the 200-mb level, for example, the net flux increased from 363 to 457 ly/day or by 26 per cent, when the cloud top was lowered from 275 to 475 mb respectively.

Again, from Fig. 3, it is seen that as the cloud top is lowered, the zone of maximum cooling also shifts downward with the rate of cooling progressively increasing. The integrated cooling of the atmospheric column increased from 1.26°C/day for the cloud top at 275 mb to 1.72°C/day for the top at 475 mb, *i.e.*, by 36 per cent, which suggests that a given variation in the height of the cloud top produces a larger change in the integrated cooling than if the base height is varied.

4. The effect of water vapour content

Since the optical depths of water vapour used in the calculation of the fluxes and cooling rates have to be computed from the observed dewpoint temperatures, it is important to know what effect a variation in dew point will have on the fluxes and cooling rates.

The water vapour concentration in the atmosphere is normally maximum very close to the surface of the earth. The effect of the dew point at the surface was therefore assessed separately by changing its value by $\pm 3^\circ\text{C}$, but keeping all other parameters the same as in the model atmosphere. The results of computation indicated that

TABLE 2
Variation in dew point at all levels

Pressure (mb)	Dew points higher by 3°C				Dew points lower by 3°C			
	Flux (ly/day)			Rate of temp. change (°C/day)	Flux (ly/day)			Rate of temp. change (°C/day)
	Upward	Down- ward	Net		Upward	Down- ward	Net	
966	961.6	852.2	109.4		961.6	834.1	127.5	
950	957.2	841.7	115.5	-1.55	957.5	824.7	132.8	-1.34
900	936.4	809.0	127.4	-0.97	938.3	796.3	142.0	-0.76
850	881.8	773.3	108.5	+1.55	882.8	762.5	120.3	+1.78
800	851.7	737.0	114.7	-0.51	853.2	725.8	127.4	-0.58
750	820.0	698.8	121.2	-0.52	821.8	688.8	133.0	-0.45
700	791.7	664.7	127.0	-0.48	794.1	655.9	138.2	-0.43
650	761.2	629.4	131.8	-0.39	764.0	621.0	143.0	-0.30
600	727.7	591.0	136.7	-0.41	731.1	584.1	147.0	-0.33
550	696.3	555.4	140.9	-0.34	700.1	548.8	151.3	-0.35
500	662.0	517.1	144.9	-0.28	666.3	511.6	154.7	-0.28
450	624.6	476.2	148.4	-0.22	629.5	471.9	157.6	-0.23
400	589.4	438.4	151.0	-0.22	594.7	434.2	160.5	-0.24
350	547.3	393.6	153.7	-0.19	553.1	390.2	162.9	-0.19
300	505.8	349.9	155.9	-0.17	512.0	346.6	165.4	-0.20
250	472.7	127.4	345.3	-15.49	480.1	118.3	361.8	-16.07
200	455.7	101.1	354.6	-0.77	464.6	93.9	370.7	-0.73
150	438.2	75.8	362.4	-0.63	448.5	69.9	378.6	-0.63
				Integrated cooling : 1.27 (°C/day)				Integrated cooling : 1.26 (°C/day)

TABLE 3
Dew points equal to dry bulb temperatures

Pressure (mb)	Flux (ly/day)			Rate of temp. change (°C/day)	Pressure (mb)	Flux (ly/day)			Rate of temp. change (°C/day)
	Upward	Down- ward	Net			Upward	Down- ward	Net	
966	961.6	857.7	103.9		500	660.5	518.1	142.4	
950	957.1	847.7	109.4	-1.40	450	623.0	476.9	146.1	-0.30
900	935.8	814.5	121.3	-0.98	400	587.8	439.0	148.8	-0.23
850	881.4	777.5	103.9	+1.43	350	545.7	394.1	151.6	-0.22
800	851.2	740.5	110.7	-0.56	300	504.0	350.3	153.7	-0.18
750	819.2	702.8	116.4	-0.47	250	470.9	128.8	342.1	-15.40
700	790.8	667.7	123.1	-0.54	200	453.6	102.4	351.2	-0.75
650	759.9	631.3	128.6	-0.45	150	435.8	76.9	358.9	-0.63
600	726.2	592.5	133.7	-0.42					
550	694.8	556.4	138.4	-0.38					
				-0.32					Integrated cooling : 1.28 (°C/day)

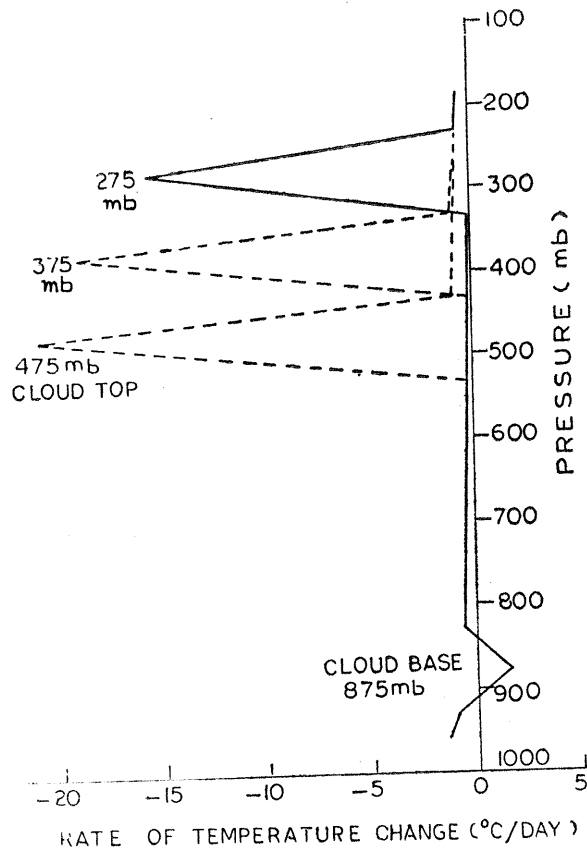

Fig. 3. Vertical profile of the rate of temperature change for various heights of the cloud top

the net flux at the surface changed from 119.2 ly/day in the model atmosphere to 118.4 and 119.7 ly/day when the surface dew point was higher and lower by 3°C respectively. The corresponding values of the cooling rate of the surface to 950-mb layer were 1.56 and $1.31^{\circ}\text{C}/\text{day}$ respectively as against $1.43^{\circ}\text{C}/\text{day}$ for the model atmosphere. However, the fluxes and cooling rates at levels above the surface remained unaffected.

The effect of a variation in the amount of water vapour in the atmosphere was examined by changing the dew point temperatures by $\pm 3^{\circ}\text{C}$ at all levels including the surface. An analysis of the results indicates that the upward flux at any level is practically unchanged (Table 2). However, the downward flux at any level, and hence the net flux, changes with the water vapour content above that level. A simultaneous decrease of 3°C in the dewpoints causes the net flux from all the levels to increase, the extent of increase being as much as 7 per cent at the surface, falling off to 2 per cent

at the 150-mb level. An increase of 3°C in the dew-points decreases the net flux by the same order. Since the effect on the net fluxes is either an increase or a decrease nearly to the same extent at any two successive levels, the cooling rates are less affected. The value of the integrated cooling is, therefore, found to remain practically constant.

An extreme case also has been considered by setting the dew points at all levels equal to the corresponding drybulb temperatures, thus simulating a state of saturation in the entire atmospheric column. The results point out that the net flux has decreased at all the levels, but that the value of the integrated cooling has remained practically constant (Table 3).

5. The effect of surface temperature

As may be seen from Table 4, a variation of only the surface temperature by $\pm 3^{\circ}\text{C}$ influences the upward flux at various levels from the surface

TABLE 4
Variation in surface temperature

Pressure (mb)	Surface temp. higher by 3°C				Surface temp. lower by 3°C			
	Flux (ly/day)			Rate of temp. change (°C/day)	Flux (ly/day)			Rate of temp. change (°C/day)
	Upward	Down- ward	Net		Upward	Down- ward	Net	
966	1000.5	857.4	143.1		923.9	828.1	95.8	
950	981.2	832.6	148.6	-1.43	933.9	832.6	101.3	-1.43
900	955.2	802.1	153.1	-0.36	919.8	802.1	117.7	-1.34
850	886.8	767.9	118.9	+2.80	877.8	767.9	109.9	+0.63
800	856.6	731.6	125.0	-0.49	848.5	731.6	116.9	-0.57
750	824.7	693.5	131.2	-0.51	817.0	693.5	123.5	-0.55
700	796.6	660.4	136.2	-0.41	789.2	660.4	128.8	-0.45
650	766.2	625.1	141.1	-0.41	759.1	625.1	134.0	-0.43
600	732.8	587.4	145.4	-0.35	726.0	587.4	138.6	-0.37
550	701.6	552.3	149.3	-0.32	694.9	552.3	142.6	-0.33
500	667.5	514.2	153.3	-0.33	661.0	514.2	146.8	-0.34
450	630.3	474.0	156.3	-0.24	623.8	474.0	149.8	-0.25
400	595.4	436.3	159.1	-0.23	589.0	436.3	152.7	-0.24
350	553.5	391.9	161.6	-0.21	547.1	391.9	155.2	-0.21
300	512.1	348.2	163.9	-0.19	505.8	348.2	157.6	-0.19
250	479.7	123.3	356.4	-15.74	473.4	123.3	350.1	-15.75
200	463.5	97.2	366.3	-0.81	457.3	97.2	360.1	-0.82
150	446.5	72.6	373.9	-0.62	440.2	72.6	367.6	-0.62
	Integrated cooling : 1.16 (°C/day)				Integrated cooling : 1.36 (°C/day)			

above especially upto the cloud base. The change in the net flux is ± 20 per cent at the surface, ± 4 per cent at 850 mb and $\pm 1-2$ per cent within and above the cloud layer. The integrated cooling of the atmospheric column increases by about 8 per cent with a 3°C decrease in the temperature of the earth's surface.

The results also point out that the cooling rate of the surface to 950-mb layer has not changed (compare values under columns 5 and 9 of Table 4 with those under column 8 of Table 1). This is so because the net fluxes at the surface and 950-mb levels have

been affected by equal amounts in the same direction as explained below :

Assume that the surface temperature increases from T_s to T_s' . Then the upward flux increases from $\sigma(T_s)^4$ to $\sigma(T_s')^4$ at the surface, σ being the Stefan-Boltzmann constant. The upward flux at the 950-mb level then changes from —

$$\sigma(T_s)^4 - \int_{T_{950}}^{T_s} R(u, T) dT \quad \text{to} \quad \sigma(T_s')^4 - \int_{T_{950}}^{T_s'} R(u, T) dT$$

where R is a function of optical depth u and temperature T (Elsasser *et al.* 1960). The downward

TABLE 5
Variation in 850 and 700 mb temperatures

Pressure (mb)	850-mb temp. higher by 3°C		850-mb temp. lower by 3°C		700-mb temp. higher by 3°C		700-mb temp. lower by 3°C	
	Net flux (ly/day)	Rate of temp. change (°C/day)	Net flux (ly/day)	Rate of temp. change (°C/day)	Net flux (ly/day)	Rate of temp. change (°C/day)	Net flux (ly/day)	Rate of temp. change (°C/day)
966	113.2	-1.35	124.8	-1.51	119.0	-1.43	119.3	-1.43
950	118.5	-0.66	130.7	-1.05	124.6	-0.85	124.9	-0.87
900	126.6	+0.99	143.6	+2.40	135.1	+1.71	135.5	+1.71
850	114.5	-0.61	114.2	-0.46	114.2	-0.52	114.6	-0.54
800	122.0	-0.49	119.9	-0.56	120.5	-0.50	121.2	-0.56
750	128.0	-0.40	126.7	-0.43	126.6	-0.49	128.0	-0.35
700	133.0	-0.42	132.0	-0.42	132.6	-0.47	132.3	-0.37
650	138.1	-0.36	137.1	-0.37	138.4	-0.34	136.8	-0.39
600	142.5	-0.32	141.6	-0.33	142.5	-0.31	141.5	-0.33
550	146.4	-0.33	145.6	-0.34	146.3	-0.33	145.6	-0.33
500	150.4	-0.24	149.7	-0.24	150.4	-0.24	149.7	-0.24
450	153.4	-0.23	152.7	-0.24	153.4	-0.23	152.7	-0.24
400	156.2	-0.21	155.6	-0.21	156.3	-0.21	155.6	-0.21
350	158.7	-0.19	158.1	-0.19	158.7	-0.19	158.1	-0.19
300	161.0	-15.75	160.5	-15.75	161.0	-15.74	160.5	-15.75
250	353.5	-0.81	353.0	-0.81	353.5	-0.81	353.0	-0.82
200	363.5	-0.62	363.0	-0.62	363.5	-0.62	363.0	-0.62
150	371.0		370.5		371.0		370.5	
	Integ. Cooling : 1.29 (°C/day)		Integ. Cooling : 1.23 (°C/day)		Integ. Cooling : 1.26 (°C/day)		Integ. Cooling : 1.26 (°C/day)	

flux at the 950-mb level does not change but that at the surface increases by an amount,

$$\int_{T_{950}}^{T_s'} R(u, T) dT - \int_{T_{950}}^{T_s} R(u, T) dT.$$

The value of the integral $\int_{T_{950}}^{T_s(T_s')} R(u, T) dT$ is

the same whether it is evaluated for optical depths with respect to the surface or the 950-mb level. Hence the net fluxes at the surface and the 950-mb level increase by an identical amount,

thus maintaining the divergence of the flux constant.

The effect brought out above will always be present for the very first layer above the surface, and will depart more from reality the thicker the layer considered. The study, therefore, points out that it is necessary to use in the computational scheme a small grid distance in the vertical, especially near the earth's surface.

6. The effect of temperatures at higher levels

An increase in the temperature of any one level causes the upward flux to increase at that level and

TABLE 5(a)
Variation in 500 and 300-mb temperatures

Pressure (mb)	500-mb temp higher by 3°C		500-mb temp lower by 3°C		300-mb temp higher by 3°C		300-mb temp lower by 3°C	
	Net flux (ly/day)	Rate of temp. change (°C/day)	Net flux (ly/day)	Rate of temp. change (°C/day)	Net flux (ly/day)	Rate of temp. change (°C/day)	Net flux (ly/day)	Rate of temp. change (°C/day)
966	119.1		119.2		119.1		119.2	
950	124.7	-1.43	124.7	-1.43	124.7	-1.43	124.8	-1.43
900	135.2	-0.86	135.2	-0.86	135.2	-0.86	135.3	-0.86
850	114.3	+1.71	114.4	+1.71	114.3	+1.71	114.3	+1.71
800	120.8	-0.53	120.9	-0.53	120.8	-0.53	120.8	-0.53
750	127.2	-0.53	127.4	-0.53	127.3	-0.53	127.3	-0.53
700	127.2	-0.41	127.4	-0.42	127.3	-0.42	127.3	-0.42
650	132.3	-0.41	132.6	-0.41	132.4	-0.42	132.4	-0.42
600	137.4	-0.36	137.7	-0.37	137.5	-0.36	137.6	-0.36
550	141.8	-0.36	142.2	-0.37	141.9	-0.36	142.0	-0.36
500	145.4	-0.30	146.4	-0.35	145.9	-0.33	146.0	-0.33
450	150.2	-0.38	149.9	-0.29	150.0	-0.33	150.1	-0.33
400	153.6	-0.28	152.4	-0.21	152.9	-0.24	153.1	-0.25
350	156.2	-0.22	155.5	-0.25	155.7	-0.23	156.0	-0.24
300	158.6	-0.20	158.1	-0.21	158.1	-0.19	158.7	-0.22
250	160.9	-0.19	160.5	-0.19	160.8	-0.22	160.6	-0.16
200	160.9	-15.75	160.5	-15.75	160.8	-16.24	160.6	-15.26
150	353.4	-0.81	353.0	-0.81	359.3	-0.77	347.1	-0.86
	363.4	-0.62	362.9	-0.62	368.9	-0.60	357.6	-0.64
	371.0		370.5		376.1		365.6	
	Integrated cooling : 1.26 (°C/day)		Integrated cooling : 1.26 (°C/day)		Integrated cooling : 1.29 (°C/day)		Integrated cooling : 1.23 (°C/day)	

at levels above it, and the downward flux to increase at that level and at levels below it. The result is, therefore, to decrease the net flux below the level and increase the net flux above it. In order to evaluate these effects, the temperatures at the levels 850, 700, 500 and 300 mb were in turn varied by $\pm 3^\circ\text{C}$. The study has shown that the change in the net flux is appreciable at all levels only when the temperature of the 850-mb level is varied (Tables 5 and 5a). A $\pm 3^\circ\text{C}$ change in the 850-mb level temperature changes the net flux at the surface by 5 per cent and that at 800-mb by 1 per cent. Varying the temperature of any single level above 850-mb has, however, only a negligible

effect on the net fluxes. It is to be inferred, therefore, that a $\pm 3^\circ\text{C}$ error in the radiosonde observations made of temperatures at these higher levels will not affect the values of the net flux and hence the cooling rates. However, the values of the temperatures at the lower levels should be more accurately known.

The effect of a temperature change at the surface as well as at higher levels simultaneously by $\pm 3^\circ\text{C}$ has been investigated. The upward, downward and net fluxes at all the levels have been found to increase or decrease by 3 to 5 per cent depending upon whether the temperatures were

TABLE 6
Variation in temperature at all levels

Pressure (mb)	Temperatures higher by 3°C			Rate of temp. change (°C/day)	Temperatures lower by 3°C			Rate of temp. change (°C/day)
	Flux (ly/day)				Flux (ly/day)			
	Upward	Downward	Net		Upward	Downward	Net	
966	1000.5	877.0	123.5		923.9	809.1	114.8	
				-1.47				-1.39
950	995.7	866.3	129.4		919.6	799.4	120.2	
				-0.88				-0.81
900	975.4	835.3	140.1		899.7	769.6	130.1	
				+1.75				+1.63
850	918.9	800.3	118.6		847.0	736.8	110.2	
				-0.56				-0.51
800	887.9	762.5	125.4		818.1	701.7	116.4	
				-0.55				-0.50
750	855.2	723.0	132.2		787.3	664.8	122.5	
				-0.44				-0.40
700	826.5	688.9	137.6		760.3	632.9	127.4	
				-0.44				-0.40
650	795.1	652.2	142.9		731.1	598.9	132.2	
				-0.38				-0.34
600	760.8	613.1	147.7		698.8	562.4	136.4	
				-0.34				-0.32
550	728.7	576.9	151.8		668.8	528.6	140.2	
				-0.35				-0.31
500	693.3	537.2	156.1		636.0	491.8	144.2	
				-0.25				-0.23
450	654.9	495.7	159.2		600.0	453.1	146.9	
				-0.25				-0.22
400	618.7	456.5	162.2		566.4	416.8	149.6	
				-0.22				-0.20
350	575.5	410.6	164.9		526.0	374.0	152.0	
				-0.20				-0.18
300	532.5	365.2	167.3		486.1	331.8	154.3	
				-16.61				-14.89
250	498.8	128.4	370.4		454.6	118.3	336.3	
				-0.86				-0.77
200	482.1	101.2	380.9		439.2	93.4	345.8	
				-0.65				-0.59
150	464.4	75.4	389.0		422.9	69.9	353.0	
				Integrated cooling : 1.33 (°C/day)				Integrated cooling : 1.19 (°C/day)

higher or lower than those of the model atmosphere, as shown in Table 6. The integrated cooling changed by ± 5 per cent.

7. Conclusions

The cloud amount has been found to have an important bearing on the rate of temperature change near the base and top of the cloud layer. The value of the integrated cooling is, however, not significantly altered with a change in the cloud amount. The rate of heating at the cloud base decreases as the base height is lowered, and the rate of cooling at the cloud top decreases as the top height is raised.

A rise in the dew-point at the surface and higher levels simultaneously, causes a decrease in the net flux everywhere, while such an increase in the air temperature results in an increase in the net fluxes. The upward flux at any level is primarily controlled by the surface temperature, but the downward flux is dependent on the water vapour concentration above the level. The temperature fluctuations at individual levels above 850-mb do not affect the net fluxes and cooling rates in the atmosphere.

The effect of dust and aerosols on the long wave radiation has not been taken into account.

This is partly justified because the model atmosphere used represents conditions during the monsoon season, when the turbidity of the atmosphere is considered to be minimum (Mani *et al.* 1965).

8. Acknowledgements

The authors wish to express their sincere thanks

to Dr. Bh. V. Ramana Murty for his interest in this study, for going through the manuscript and for making useful suggestions. Thanks are also due to Shri K. V. S. Madhavan for typing the manuscript and to our colleagues in the Drawing Section for preparing the diagrams.

REFERENCES

- | | | |
|--|------|---|
| Elsasser, W. M. and Culbertson, M. F. | 1960 | <i>Met. Monogr.</i> 23 , pp. 43. |
| Godbole, R. V. and Kelkar, R. R. | 1969 | <i>Indian J. Met. Geophys.</i> , 20 , 1, pp. 1-10. |
| Mani, A., Sreedharan, C. R. and Srinivasan, V. | 1965 | <i>J. Geophys. Res.</i> , 70 , 18, pp. 4529-36. |
| Rao, Venkateshwara, D. | 1955 | <i>Indian J. Met. Geophys.</i> , 6 , 4, pp. 299-316. |
-