

## An indigenous state-of-the-art High Wind Speed Recording (HWSR) system for coastal meteorological observatories

R. D. VASHISTHA, K. N. MOHAN and P. S. BIJU

*India Meteorological Department, Pune, India*

*(Received 28 October 2009, Modified 26 February 2010)*

**e mail : ramdhanvashistha@yahoo.co.in**

**सार** – मौसम वैज्ञानिकों के लिए पवन की गति और दिशा का निरंतर और सटीक मॉनीटरन करना, विशेषकर चक्रवातीय तूफानों के दौरान, बहुत ही महत्वपूर्ण है। मौसम वैज्ञानिकों को पवन के मॉनीटरन से चक्रवात के मार्ग और उसके विनाशकारी प्रभाव का सही अनुमान लगाने में भी मदद मिलती है। मौजूदा सभी पवन मॉनीटरन और संचयन प्रणालियों का सबसे बड़ा नुकसान यह है कि इसमें बिजली की बहुत अधिक खपत होती है और इसलिए ये प्रणालियाँ चक्रवातीय तूफान के दौरान बिजली की आपूर्ति बंद हो जाने के कारण सुविधाजनक नहीं रहती। अतः इस शोध पत्र में शोधकर्ताओं द्वारा भारत के पूर्वी और पश्चिमी तटों पर तटीय मौसम विज्ञानिक वेधशालाओं के लिए कम लागत, कम बिजली की खपत, अधिक सटीक और अनुरक्षण मुक्त उच्च पवन गति रिकॉर्डिंग (एच. डब्ल्यू. एस. आर.) प्रणाली को डिजाइन करने और उसका विकास करने का प्रयास किया गया है। इसी प्रकार की एक प्रणाली को सफल क्षेत्रीय प्रयोगों के बाद उड़ीसा के तट पर मौसम कार्यालय पुरी में स्थापित किया गया है तथा भारत के पूर्वी और पश्चिमी तटों पर ऐसे 19 और केन्द्र स्थापित करने का प्रस्ताव है। यह प्रणाली विश्व मौसम विज्ञान संगठन (डब्ल्यू. एम. ओ., 1992) की सिफाशियों के अनुसार पवन के ऑकड़ों की प्रचलनात्मक सटीकता और वेक्टर औसत के अनुरूप है। इस शोध-पत्र में इस प्रणाली के डिजाइन के पहलुओं और इसके विकास की संभावनाओं को प्रस्तुत किया गया है।

**ABSTRACT.** The continuous and accurate monitoring of wind speed and direction is of utmost importance to weatherman, particularly during the cyclonic storms. Wind monitoring also helps the meteorologists in tracking the cyclone accurately and estimating their devastating potential. One major disadvantage of all the existing wind monitoring and storing systems is their huge consumption of power, and hence are not suitable during cyclonic storms due to mains power supply failure. So an attempt has been made by the authors to design and develop a low cost, low power, more accurate and maintenance free High Wind Speed Recording (HWSR) System for the coastal meteorological observatories along the East and West Coasts of India. One such system after successful field trials have been installed at Meteorological Office, Puri in the Orissa coast, and 19 more stations are proposed along East and West Coasts of India. The system meets the operational accuracy requirements and vector averaging of wind data as recommended by the World Meteorological Organisation (WMO, 1992). The system design aspects and scope for expansion have been presented in this paper.

**Key words** – HWSR, WMO, Sensors, potentiometer.

### 1. Introduction

India Meteorological Department established 20 important coastal observatories along the East and West Coasts of India for the continuous monitoring of wind speed and direction. At present these stations are not equipped with suitable and trouble-free automated observing instruments for wind data as recommended by World Meteorological Organisation (WMO, 1992). So the authors have designed and developed a high wind speed recording system for the continuous monitoring of wind speed and direction. The system is based on state-of-the-art technology with a very good attention to the power consumption which is a major factor affecting the observational equipments at the coastal stations during the cyclonic period. The main components of the system are

data logger and sensors which need very less power requirement and hence a 60 AH battery can continuously operate the system for a minimum of 25 days without mains power. A solar panel of 12V/30W trickle charges the battery and years of uninterrupted operation of the system is ensured.

Authors have designed a new generation optical anemometer with serial output for the measuring the high wind speed, which is equally compatible with the ultrasonic wind instruments in accuracy and reliability. The range of measurement is 0-130 knots

The system has data storage capacity of 10 years for one-minute averaged data of wind speed and direction. The stored data can be retrieved through USB port and a

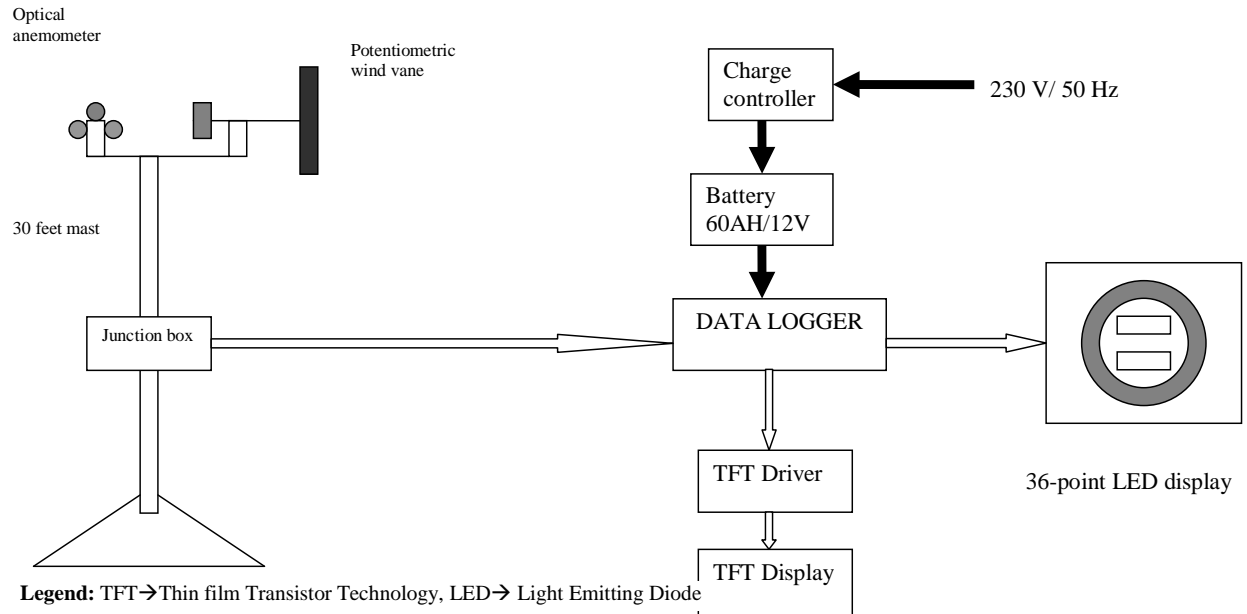

Fig. 1. Complete system of HWSR

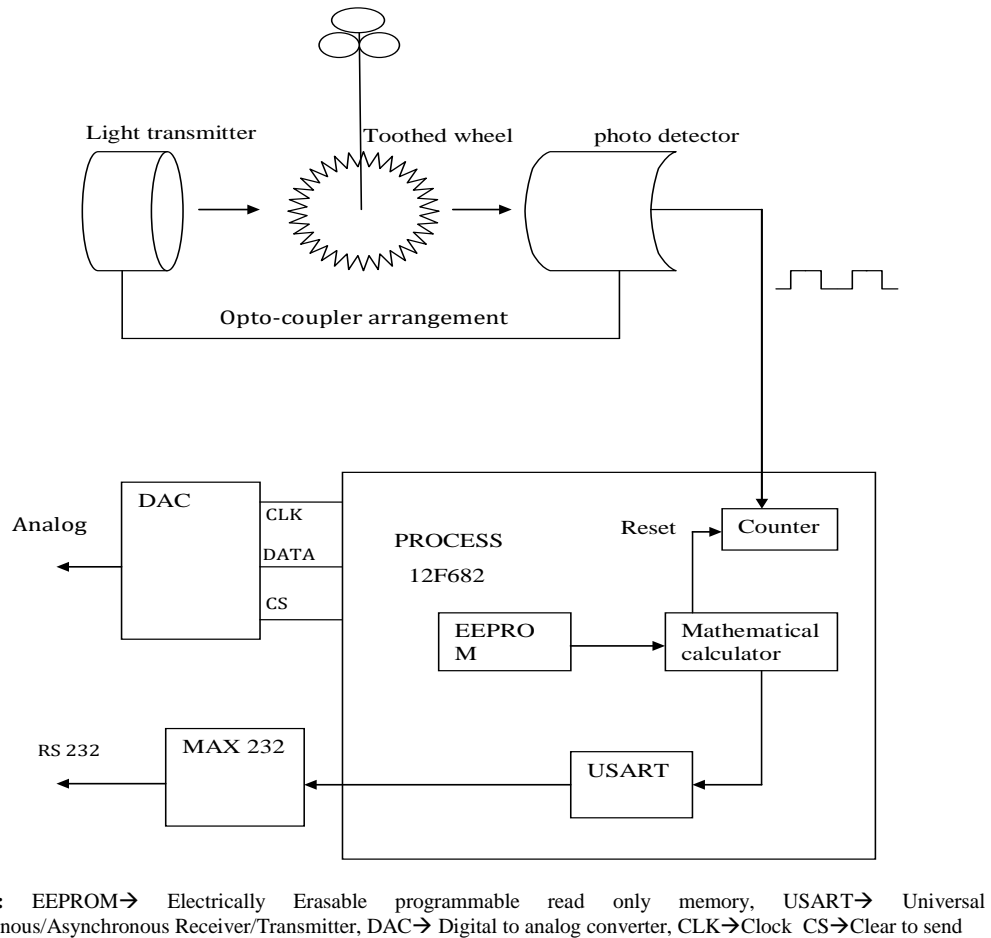
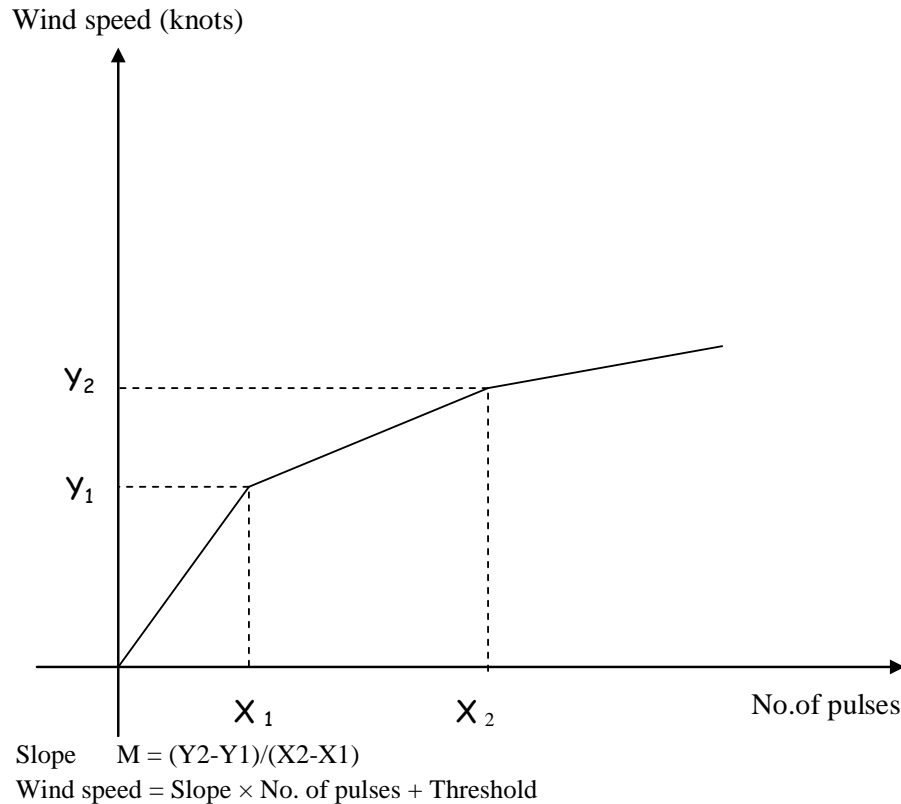

Fig. 2. Optical anemometer (Schematic diagram)



**Fig. 3.** Calibration of anemometer using piece-wise linearity

hard copy of data could be obtained on an attached laser printer.

**2. System description**

The complete HWSR system is depicted in Fig. 1. The main components comprises (i) Sensors at field site (ii) Data logger (iii) TFT (Thin film Transistor Technology) driver with TFT display (iv) 36-point compass LED display (v) Laser printer and (vi) SMF battery with charge controller.

*2.1. Sensors*

The indigenous HWSR system utilises IMD make sensors, which is a potentiometric wind vane for the measurement of wind direction and optical anemometer for wind speed, ultrasonic wind sensor as a alternative.

*2.1.1. Potentiometric wind vane*

The sensor used for measurement of wind direction is an IMD-make potentiometric wind vane. The potentiometer in the wind vane is a servo-micro torque potentiometer and has a maximum resistance of 10 kilo-

ohms over an end gap of about 4 degrees. The potentiometer is coupled to the wind vane shaft so as to give a resistance output increasing linearly with the increasing of wind direction. Thus, 0 K $\Omega$  corresponding to the north, 2.5 K $\Omega$  for east, 5 K $\Omega$  for south, 7.5 K $\Omega$  for west and the variation of 0-360 degree corresponds to 0 to 10 kilo ohms.

*2.1.2. Optical anemometer*

Optical anemometer gives digital as well as analog outputs with respect to the wind speed in knots. Suitable scaling has been provided in the data logger for other units, such as Kilometers per hour, meters per seconds etc. Fig. 2 shows the schematic diagram of the optical anemometer. The basic operating element is an opto-coupler, which is having a transmitter and a receiver with a toothed wheel connected to the shaft of the cup anemometer. The receiver, which is a photo detector, receives infrared light from the transmitter through the gaps between the teeth of the wheel generates pulses proportional to the true wind speed. These pulses are counted by an inbuilt counter in the 16-bit microprocessor (Microchip make model no. 12F682). The counter resets

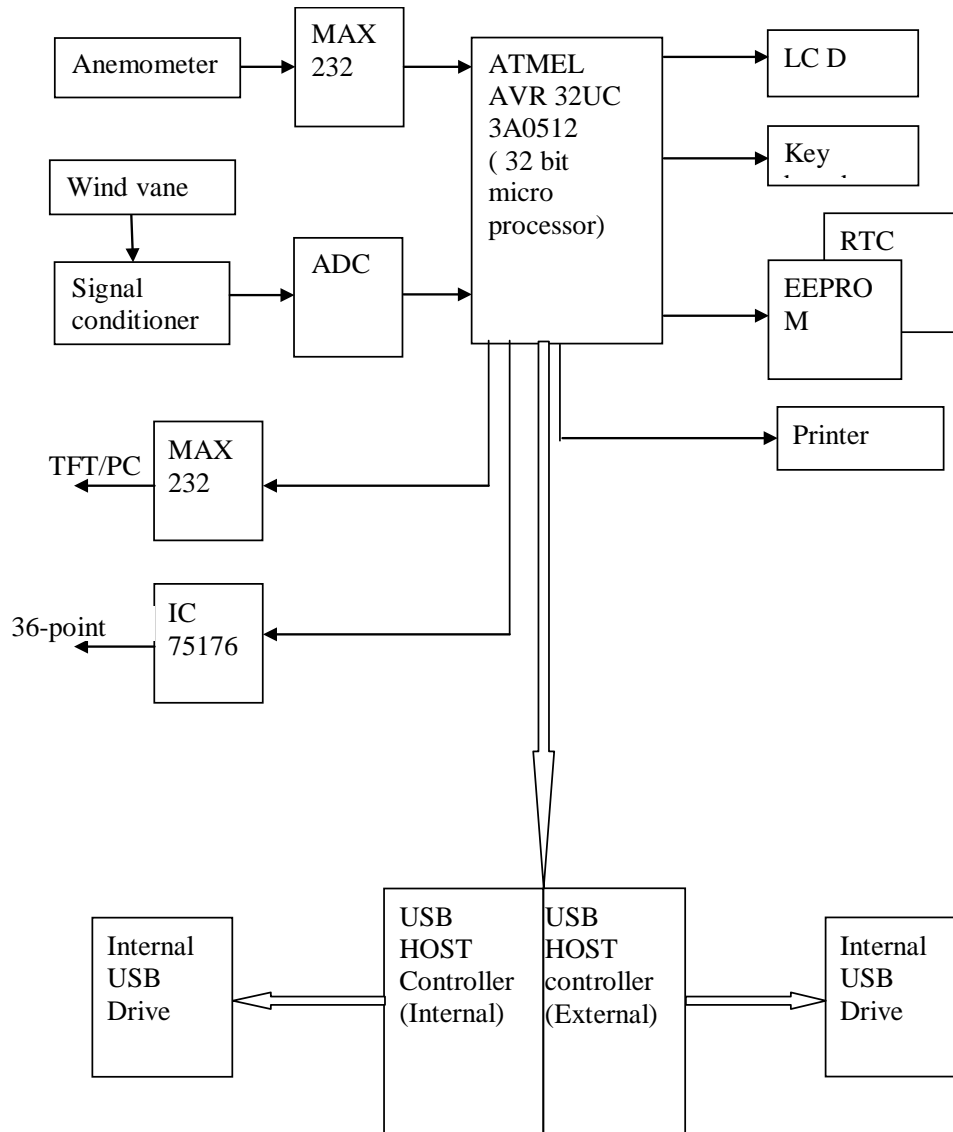

**Legend:** USB → Universal serial bus, EEPROM → Electrically Erasable programmable read only memory, RTC → Real time clock, ADC → Analog to Digital converter, LCD → Liquid crystal display, TFT → Thin film Transistor Technology

**Fig. 4.** HWSR data logger (Block diagram)

**TABLE 1**

**Relationship between number of pulses and corresponding true wind speed of optical anemometer in HWSR**

No. of Pulses	22	56	76	165	200	290	340	396	525	600	650	790
Wind speed in knots	2.5	6.3	8.5	18	22	33	38.6	45	60	68	72	89

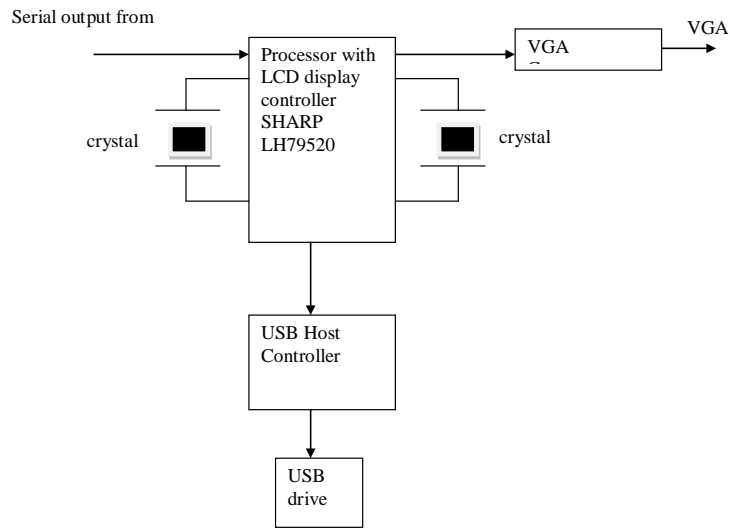

Legend: USB → Universal serial bus, LCD → Liquid crystal display, VGA → Video Graphics adaptor

Fig. 5. Block diagram of TFT driver

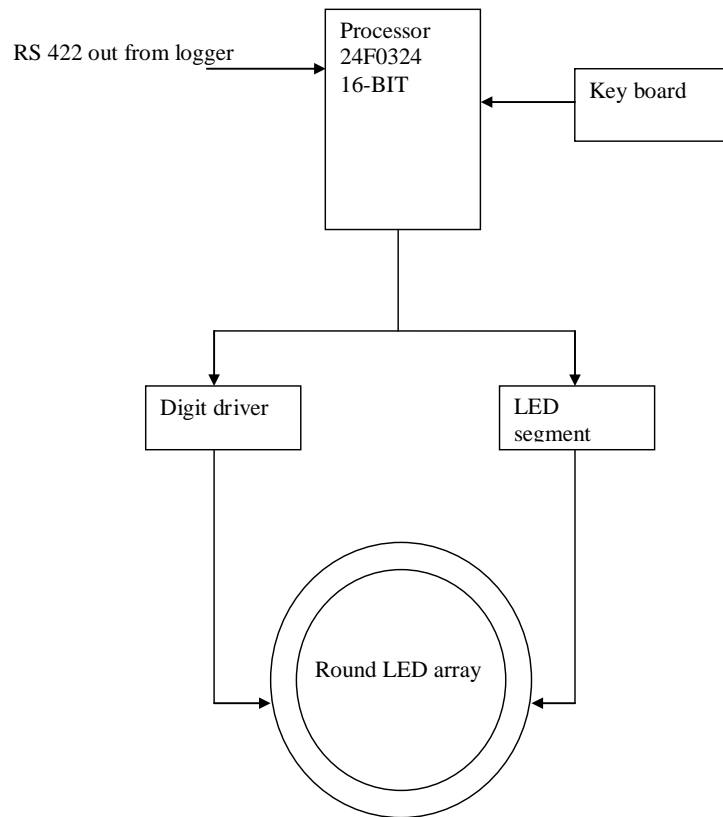

Legend : LED → Light emitting diode,

Fig. 6. Block diagram of 36-point compass display

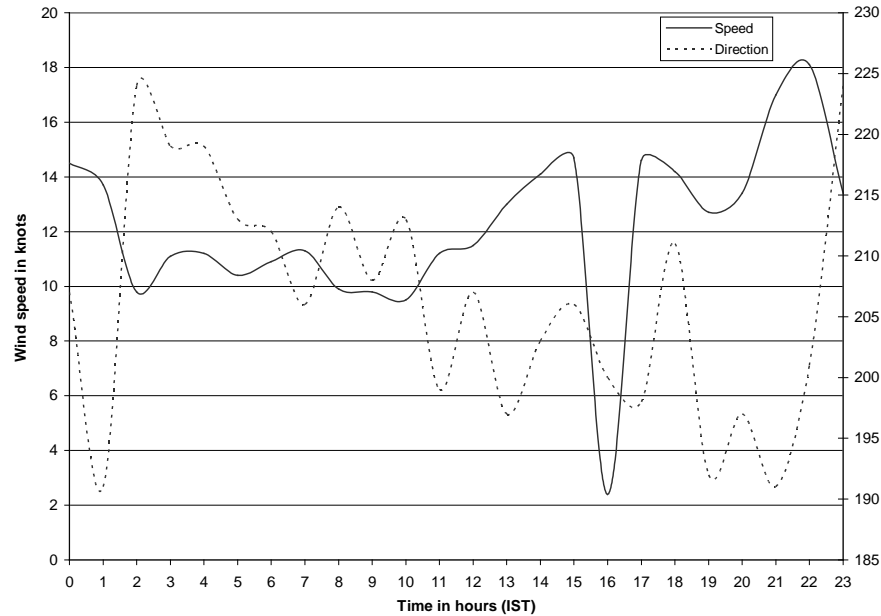

Fig. 7. Hourly minimum wind speed at M.O. Puri on 22 July 2008

every 250 milli seconds, and hence 4 samples per second can be measured. A piecewise linearity (Yama Guchi, 2007) is derived between the wind speed in knots and no. of pulses from the anemometer during the course of calibration in wind tunnel. The required range of measurement is fixed as 0-130 knots. This range is obtained in three segments with three slopes due to the different levels of friction at different stages as shown in Fig. 3. Wind speed can be calculated by using the mathematical formula:

$$Y = MX + C$$

where, Y is the wind speed in knots, X is the number of pulses, M is the slope of the segment and C is threshold speed. The values of slopes for the three segments are stored in the inbuilt EEPROM of the processor and all calculations are made by the mathematical calculator, which is register in the processor contains all the programs. In built USART (Universal synchronous/Asynchronous Receiver/Transmitter) generates the TTL logic (5 Volts  $\rightarrow$  High and 0 Volts  $\rightarrow$  Low) and is converted into serial by using an external level shifter (IC No. MAX 232). Analog out put is generated by using an external Digital to Analog converter (DAC IC No.4821).

The following table shows the average number of generated pulses from the optical anemometer at different wind speeds in knots. These values are obtained at the time of calibration of the anemometer in wind tunnel.

The above values are tabulated within range of calibration of the existing wind tunnel of IMD. But the range of measurement of optical anemometer is tested with the help of high rpm motors, and proved that the system can give a maximum of 130 knots.

## 2.2. The system design and data logging

The resistive output of potentiometric wind vane is converted in to digital signal in TTL logic acceptable to the processor by the use of a signal conditioner and an analog to digital converter (ADC). Since the output of optical anemometer is serial form a level shifter (IC No. MAX 232) is utilized to convert it in to TTL logic. The processor used is ATMEL make AVR 32 UC 3A0512, which is a 32-bit processor and its programming can be done through the design tools available in the web site (<http://www.atmel.com>). The data logger is having inbuilt  $128 \times 64$  graphical LCD display and key board for configuration of the entire system, calibration of sensors, monitoring and retrieving the past data etc. The system is designed for retrieving the data in an USB stick. So two USB host controllers are built in to the system, one is for internal USB drive and the other for external USB drive. In order to avoid the data corruption while transferring, an EEPROM is used for the temporary data storage. One day full data will be stored in EEPROM, and every day at 0000 hrs the data will be transferred to the internal USB storage. The current storage capacity is 2GB, which can store 10 years of one minute averaged data of wind speed

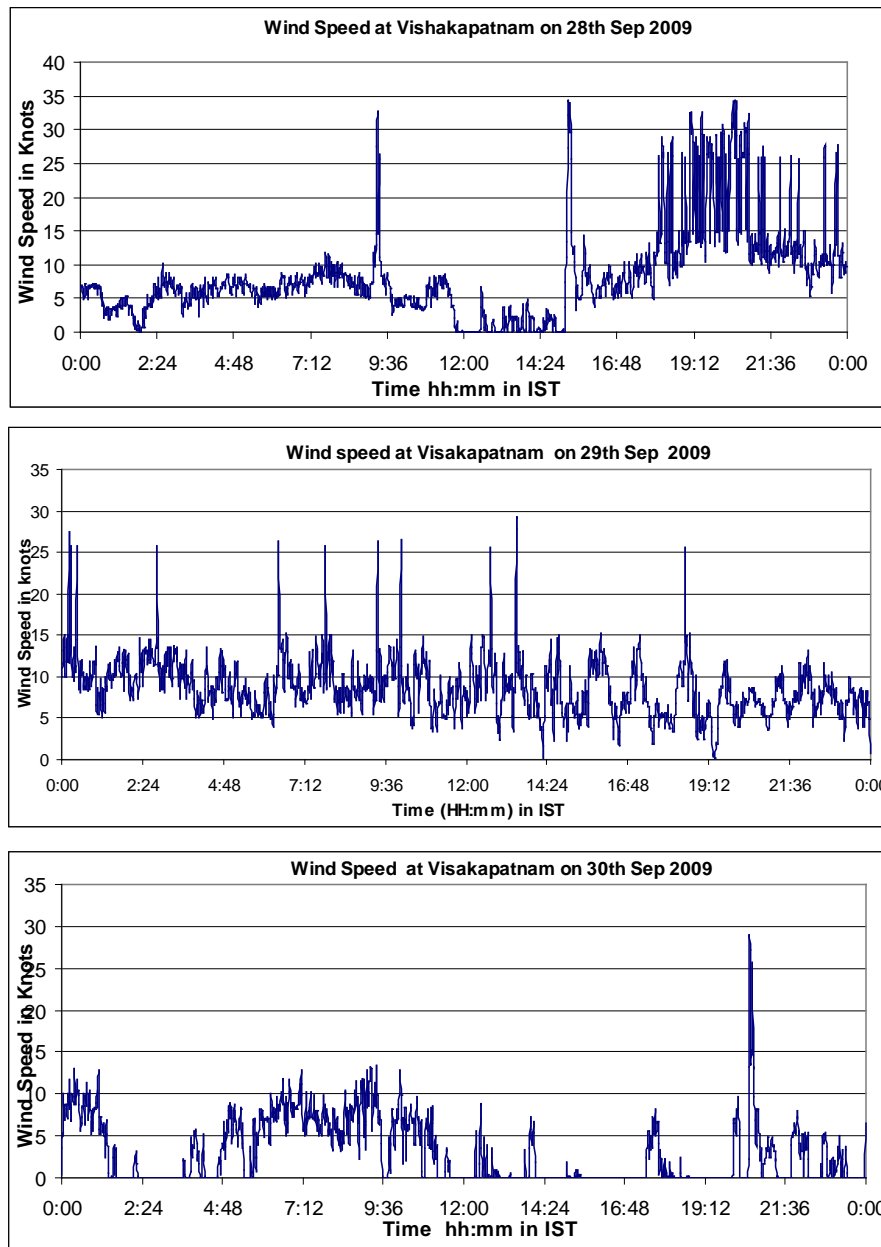

Fig. 8. Wind data pertaining to Deep Depression over Visakhapatnam coast during 28-30 Sep-2009

and direction. Hard copy of data also can be made by using laser printers. The data logger is interfaced with a 36-point compass LED display through an RS 422 interface (IC No. 75176) for the numerical display of instantaneous, two-minute, and ten-minute averaged values of wind speed and direction and the graphical display is available on a TFT screen through an RS 232 interface (IC No. MAX 232). The schematic diagram of data logger is shown in Fig. 4.

### 2.3. TFT driver with TFT display

A TFT 17" display is provided in the system for the continuous graphical display of wind speed and direction. A TFT driver is interfaced with the data logger for converting the serial output in to VGA output. The schematic of the TFT driver is shown in Fig. 5. The VGA conversion and storage of downloaded data from the data logger is controlled by a 32-bit processor (SHARP make

No. LH79520). In addition to graphical display, information of maximum and minimum wind speed in a day and 36-point compass display of wind direction also can be seen in the TFT display. Both graphical and numerical data can be downloaded from the data logger in to the USB host controller in the TFT driver for analysis and other meteorological purposes. TFT display is having touch screen facility for user friendly interaction with the system.

#### 2.4. 36-point compass LED display

The data logger is interfaced with a 36-point compass round LED display for viewing the instantaneous, two-minute and ten-minute averaged values of wind speed and direction. Instantaneous direction of wind and the trace for the previous 10 minutes also can be seen on the circular array of LED in the display. Fig. 6 shows the schematic diagram of the 36-point compass LED display. The RS 422 signal from the data logger is fed in to the 16-bit processor (No. 24F0324) and then to the LED segment driver and digit driver for display of the wind data in a round display.

#### 2.5. Data quality evaluation

The data collected from HWSR system installed at Puri has been compared with the wind data of conventional observatories where wind is measured by a CCA (Cup Counter Anemometer). The results show a good agreement between the data collected from HWSR and the data available from a conventional observatory. However, the data could not be compared in a microscopic level as the data from conventional observatory is recorded only once in three hours (synoptic measurement). The graphs in Fig. 7 show the hourly minimum wind speed and its direction on 22 July 2008 obtained from the HWSR system installed at Meteorological Office, Puri. The data is exactly matching

with the system of wind prevailing (taken from cup Counter Anemometer) in the Orissa coast on that day.

Data pertaining to a deep depression over VIZAG coast from 28<sup>th</sup> - 30<sup>th</sup> September 2009 has been presented in Fig. 8. It has reached highest speed up to 34 knots, which agrees well with synoptic observations.

### 3. Conclusion

The IMD developed HWSR equipment installed at Meteorological Office, Puri has provided a good platform for providing a trouble-free HWSR system at all the important coastal sites along the East and West Coasts of India where monitoring of high wind during depressions and cyclonic storms is of utmost importance. The system is capable of working trouble free without AC mains supply which is prone to failures during adverse weather conditions. It is proposed to install such systems at 20 more coastal stations in a phased manner. Although the system utilizes IMD make wind sensors, ultrasonic wind sensors could also be interfaced with the present system.

#### Acknowledgement

Authors are grateful to AVM Dr. Ajit Tyagi, DGM, who took keen interest and encouraged the authors in designing the system.

#### References

<http://www.atmel.com>

www.michocip.com, "Microchip DSPIC user manual".

WMO, 1992, "Guide to Meteorological instruments and methods of observation". Chapter-5, p-7

Yama Guchi, N. O. E., 2007, "Piecewise linearization method for arbitrary curves by relaxation method to line label", Institute of image electronic engineers of Japan, **36**, 6, 863-868.